

HYBRID-HIGH RELIABILITY RADIATION HARDENED DC-DC CONVERTER

28V Input, Triple Output

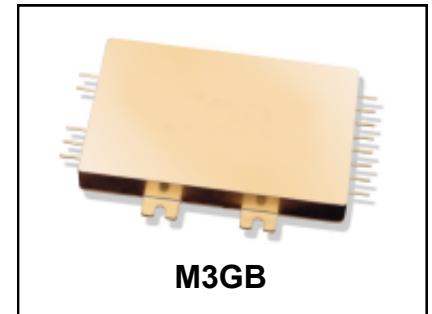

Description

The M3GB-Series of DC-DC converters are second generation design of the legacy M3G-Series product family but with enhanced overall performance. M3GB-Series is form, fit and functional equivalent to the first generation M3G-Series. It is designed to be backward compatible to the M3G-Series. Much the same as the original M3G-Series, these converters are radiation hardened, high reliability converters designed for extended operation in hostile environments. Their small size and low weight make them ideal for applications such as geostationary earth orbit satellites and deep space probes. They exhibit a high tolerance to total ionizing dose, single event effects and environmental stresses such as temperature extremes, mechanical shock, and vibration.

The converters incorporate a fixed frequency single ended forward topology with magnetic feedback and an internal EMI filter that utilizes multilayer ceramic capacitors that are subjected to extensive lot screening for optimum reliability. These converters are capable of meeting the conducted emissions and conducted susceptibility requirements of MIL-STD-461C without any additional components. External inhibit and synchronization input and output allow these converters to be easily incorporated into larger power systems. They are enclosed in a hermetic 3" x 2" x 0.475" package constructed of an Aluminum-Silicon-Carbide (AlSiC) base and an Alloy 48 ring frame and they weigh less than 100 grams. The package utilizes rugged ceramic feed-through copper core pins and is sealed using parallel seam welding.

Manufactured in a facility fully qualified to MIL-PRF-38534, these converters are fabricated utilizing DLA Land and Maritime qualified processes. For available screening options, refer to device screening table in the data sheet.

Non-flight versions of the M3GB-Series converters are available for system development purposes. Variations in electrical specifications and screening to meet custom requirements can be accommodated.

Features

- Total Dose > 200 kRads(Si)
typically usable to > 300 kRads(Si)
- SEE Hardened to LET up to 82 MeV·cm²/mg
- Internal EMI filter; Converter Capable of meeting MIL-STD-461C CE03
- Low Weight < 100 grams
- Magnetically Coupled Feedback
- 18V to 50V DC Input Range
- Up to 33W Output Power
- Triple Output Models Include
Main: +3.3V
Auxiliary: ±12V
- Main Output Isolated from Auxiliary Outputs
- High Efficiency - to 75%
- -55°C to +125°C Operating Temperature Range
- 100MΩ @ 100VDC Isolation
- Under-Voltage Lockout
- Synchronization Input and Output
- Short Circuit and Overload Protection
- Adjustable Output Voltage
- External Inhibit
- > 6,000,000 hour MTBF

Applications

- Geostationary Earth Orbit Satellites (GEO)
- Deep Space Satellites / Probes
- Strategic Weapons and Communication System

Circuit Description

The M3GB-Series converters utilize a single-ended forward topology with resonant reset. The nominal switching frequency is 500kHz. Electrical isolation and tight output regulation are achieved through the use of a magnetically coupled feedback. Voltage feed-forward with duty factor limiting provides high line rejection.

An internal EMI filter reduces the conducted emissions to less than 5mA rms on the input power leads. A two-stage output filter reduces the typical output ripple to less than 20mV peak-to-peak.

The main (+3.3 volt) output is regulated by the control loop and typically exhibits better than 1% regulation. The auxiliary (± 12 volt) outputs are maintained through tight coupling in the power transformer and main output filter inductor and typically exhibit better than 5% regulation. The main output and auxiliary outputs are isolated from each other.

Output power is limited under any load fault condition to approximately 125% of rated. An overload condition causes the converter output to behave like a constant current source with the output voltage dropping below nominal. The converter will resume normal operation when the load current is reduced below the current limit point. This protects the converter from both overload and short circuit conditions.

An under-voltage lockout circuit prohibits the converter from operating when the line voltage is too low to maintain the output voltage. The converter will not start until the line voltage rises to approximately 16.5 volts and will shut down when the input voltage drops below 15.3 volts. The 1.2V of hysteresis reduces the possibility of line noise interfering with the converter's start-up and shut down.

An external inhibit port is provided to control converter operation. The nominal threshold relative to the input return (Pin 2) is 1.4V. If 2.0 volts or greater are applied to the Inhibit pin (Pin 3) then the converter will operate normally. A voltage of 0.8V or less will cause converter to shut-down. The pin may be left open for normal operation and has a nominal open circuit voltage of 4.0V.

Synchronization input and output allow multiple converters to operate at a common switching frequency. Converters can be synchronized to one another or to an externally provided clock. This can be used to eliminate beat frequency noise or to avoid creating noise at certain frequencies for sensitive systems.

Design Methodology

The M3GB-Series was developed using a proven conservative design methodology which includes selecting radiation tolerant and established reliability components and fully de-rating to the requirements of MIL-STD-1547 and MIL-STD-975 (except for the CDR type ceramic capacitors, where capacitors with 50V ratings may be used with voltage stresses of less than 10V). Careful sizing of decoupling capacitors and current limiting resistors minimizes the possibility of photo-current burn-out. Heavy de-rating of the radiation hardened power MOSFET virtually eliminates the possibility of SEGR and SEB. A magnetic feedback circuit is utilized instead of opto-couplers to minimize temperature, radiation and aging sensitivity. PSpice and RadSpice were used extensively to predict and optimize circuit performance for both beginning and end-of-life. Thorough design analyses include Radiation Susceptibility (TREE), Worst Case, Stress, Thermal, Failure Modes and Effects (FMEA) and Reliability (MTBF).

Specifications

Absolute Maximum Ratings		Recommended Operating Conditions	
Input Voltage	-0.5V _{DC} to +80V _{DC}	Input Voltage range	+18V _{DC} to +60V _{DC}
Output power	Internally limited	Input Voltage range ¹	+18V _{DC} to +50V _{DC}
Lead Temperature	+300°C for 10 seconds	Output power	0 to Max. Rated
Operating temperature	-55°C to +135°C	Operating temperature ²	-55°C to +125°C
Storage temperature	-55°C to +135°C	Operating temperature ¹	-55°C to +70°C

¹ Meets de-rating per MIL-STD-975

² For operation at +125°C see table Note 14

Electrical Performance Characteristics

Parameter	Group A Subgroup	Conditions -55°C ≤ T _C ≤ +85°C V _{IN} = 28V DC ± 5%, C _L = 0 unless otherwise specified	Limits			Unit
			Min	Nom	Max	
Input voltage (V _{IN})	1,2,3	Note 2	18	28	50	V
Output voltage (V _{OUT}) Main ±Aux	1	I _{OUT} = 100% rated load, Note 5	3.28 ±11.60	3.3 ±12.00	3.32 ±12.40	V
Main ±Aux	2,3		3.24 ±11.40		3.36 ±12.60	
Output power (P _{OUT})	1,2,3	V _{IN} = 18, 28, 50 Volts, Note 2	0		33.2	W
Output current (I _{OUT}) Main ±Aux	1,2,3	V _{IN} = 18, 28, 50 Volts, Notes 2,3,4,5	400 ±83		4000 ±833	mA
Line regulation (VR _{LINE}) Main ±Aux	1,2,3	V _{IN} = 18, 28, 50 Volts I _{OUT} = 10, 50%, 100% rated, Notes 5	-10 -150		10 150	mV
Load regulation (VR _{LOAD}) Main ±Aux	1,2,3	I _{OUT} = 10%, 50%, 100% rated V _{IN} = 18, 28, 50 Volts, Notes 5, 13	-25 -300		25 300	mV
Cross regulation (VR _{CROSS}) Main ±Aux	1,2,3	V _{IN} = 18, 28, 50 Volts I _{OUT} = 2.5A to 1A and 2.5 to 4A on main and ± half rated on aux. outputs	-4.0		+4.0	%
Input current (I _{IN})	1,2,3	I _{OUT} = 0, Pin 3 open		60	80	mA
		Pin 3 shorted to Pin 2			5.0	

For Notes to Electrical Performance Characteristics, refer to page 5

Electrical Performance Characteristics (continued)

Parameter	Group A Subgroup	Conditions -55°C ≤ T _C ≤ +85°C V _{IN} = 28V DC ± 5%, C _L = 0 unless otherwise specified	Limits			Unit
			Min	Nom	Max	
Output ripple (V _{RIP}) Main ±Aux	1,2,3	V _{IN} = 18, 28, 50 Volts I _{OUT} = 100% rated load, Notes 5, 6		10 20	30 60	mVp-p
Switching frequency (F _S)	1,2,3	Sych. Input (Pin4) open	475	500	525	kHz
Efficiency (E _{FF})	1,2,3	I _{OUT} = 100% rated load Note 5	72	75		%
Inhibit Input open circuit voltage drive current (sink) voltage range		Note 1	3.0 -0.5		5.0 100 50	V µA V
Synchronization input frequency range pulse high level pulse low level pulse transition time pulse duty cycle		Ext. Clock on Sync. Input (Pin 4) Note 1	450 4.0 -0.5 40 20		600 10 0.5 80	kHz V V V/µs %
Current limit point Expressed as a percentage of full rated output power	1,2,3	V _{OUT} = 90% of Nominal, Note 5	105		150	%
Power dissipation, load fault (P _D)	1,2,3	Short Circuit, Overload, Note 8			18	W
Under Voltage Threshold Release (On) (UVR) Lockout (OFF) (UVLO)	1,2,3		16.3 15.0		16.7 15.6	V
Output response to step load changes (V _{TLD})	4,5,6	Half Load to/from Full Load, Notes 5, 9	-300		300	mVpk
Recovery time, step load changes (T _{TLD})	4,5,6	Half Load to/from Full Load, Note 5,9,10			100	µs
Output response to step line changes (V _{TLN})		22V to/from 34V I _{OUT} = 100% rated load, Notes 1,5,11	-300		300	mVpk
Recovery time, step line changes (T _{TLN})		22V to/from 34V I _{OUT} = 100% rated load, Notes 1,5,10,11			100	µs
Turn-on Response Overshoot (V _{OS}) Main ±Aux Turn-on Delay (T _{DLY})	4,5,6	10% Load, Full Load, Notes 5,12	1.0		100 100 5.0	mV mV ms
Capacitive load (C _L) Main ±Aux		I _{OUT} = 100% rated load, No effect on DC performance, Notes 1, 5, 7			1000 200	µF

For Notes to Electrical Performance Characteristics, refer to page 5

Electrical Performance Characteristics (continued)

Parameter	Group A Subgroup	Conditions -55°C ≤ T _C ≤ +85°C V _{IN} = 28V DC ± 5%, C _L = 0 unless otherwise specified	Limits			Unit
			Min	Nom	Max	
Line rejection	Main	I _{OUT} = 100% rated load DC to 50kHz, Notes 1,5	40	50		dB
	±Aux		30	40		
Isolation	1	Input to Output or any pin to case Except Pin 10, test @100V _{DC}	100			MΩ
Device Weight					100	g
MTBF		MIL-HDBK-217F2, SF, 35°C	6 x 10 ⁶			Hrs

Notes: Electrical Performance Characteristics Table

- Parameter is tested as part of design characterization or after design changes. Thereafter, parameter shall be guaranteed to the limits specified.
- Parameter verified during line and load regulation tests.
- Although operation with no load is permissible, light loading on the main (+3.3 volt) output may cause the output voltage of the auxiliary outputs (±12 volt) to drop out of regulation. It is therefore recommended that at least 200 mA or 20 percent of the total output power, whichever is greater, be taken from the main (+3.3 volt) output.
- Although operation with no load is permissible, heavy loading on the main (+3.3 volt) output may cause the output voltage of the auxiliary outputs (±12 volt) to rise out of regulation. It is therefore recommended that at least 50 mA or 20 percent of the total output power, whichever is greater, be taken from the auxiliary (±12 volt) outputs.
- Unless otherwise specified, "Rated" load is 13.2W on the main (+3.3 volt) output and 10 watts each on the aux (±12 volt) outputs.
- Guaranteed for a D.C. to 20MHz bandwidth. Tested using a 20kHz to 10MHz bandwidth.
- Capacitive load may be any value from 0 to the maximum limit without compromising dc performance.
A capacitive load in excess of the maximum limit may interfere with the proper operation of the converter's overload protection, causing erratic behavior during turn-on.
- Overload power dissipation is defined as the device power dissipation with the load set such that V_{OUT} = 90% of nominal.
- Load step transition time ≥ 10 μs.
- Recovery time is measured from the initiation of the transient to where V_{OUT} has returned to within ±1% of its steady state value.
- Line step transition time ≥ 100 μs.
- Turn-on delay time from either a step application of input power or a logic low to a logic high transition on the inhibit pin (pin 3) to the point where V_{OUT} = 90% of nominal.
- Load is varied for output under test while the remaining outputs are loaded at 50% of rated. Regulation relative to output voltage at 50% rated load.
- Although operation at temperatures between +85°C and +125°C is guaranteed, no parametric limits are specified.

Radiation Performance Characteristics

Test	Conditions	Min	Typ	Unit
Total Ionizing Dose (Gamma)	MIL-STD-883, Method 1019 Operating bias applied during exposure, Full Rated Load, $V_{IN} = 28V$	200	300	kRads (Si)
Dose Rate (Gamma Dot) Temporary Saturation Survival	MIL-STD-883, Method 1023 Operating bias applied during exposure, Full Rated Load, $V_{IN} = 28V$ (supported by analysis)	1E8 4E10	1E11	Rads (Si)/sec
Neutron Fluence	MIL-STD-883, Method 1017 (supported by analysis)	8E12	1E13	Neutrons/cm ²
Single Event Effects SEU, SEL, SEGR, SEB	Heavy ions (LET) Operating bias applied during exposure, Full Rated Load, $V_{IN} = 18V, 28V, 50V$	82		MeV·cm ² /mg

Fig 1. Block Diagram

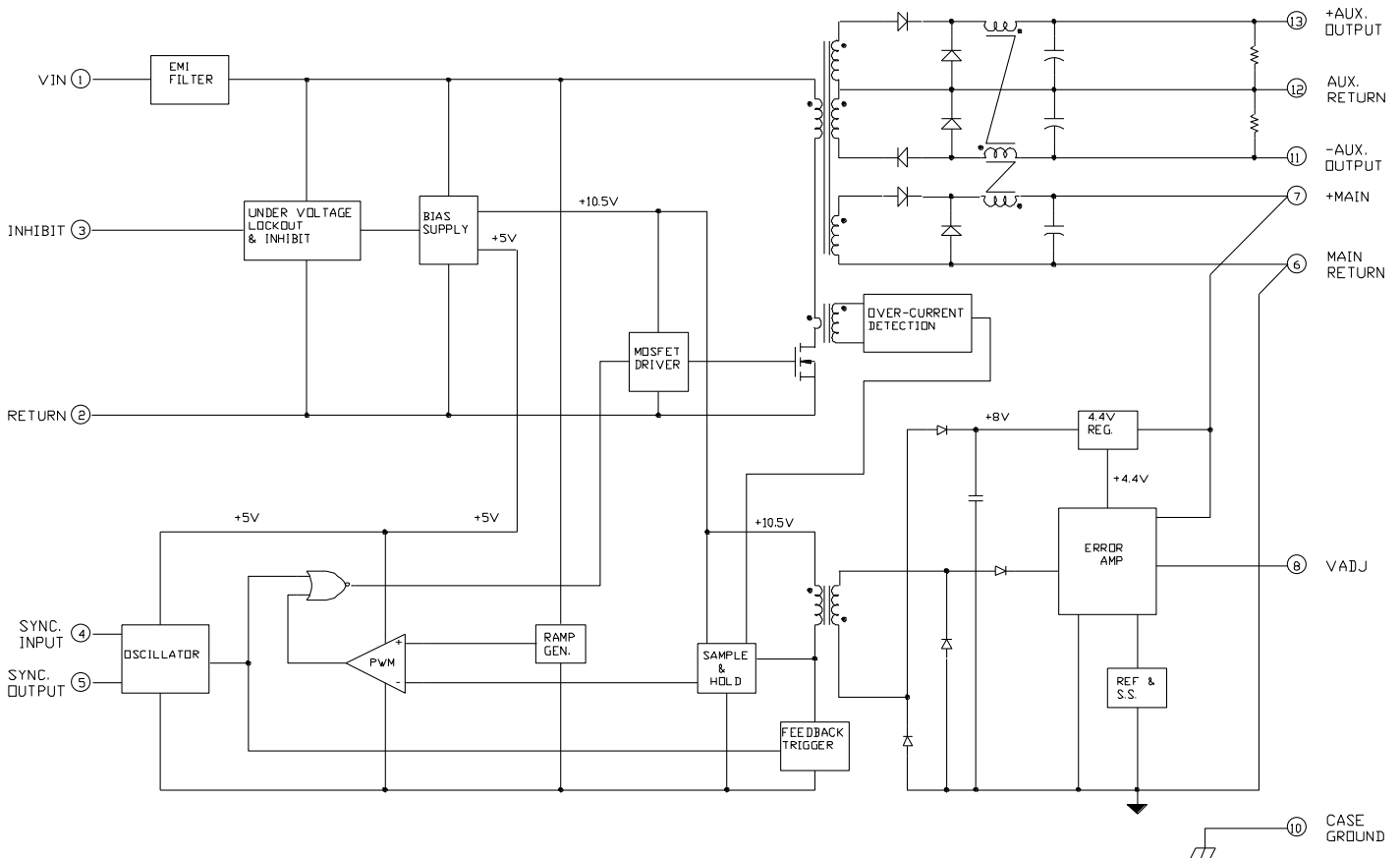

Application Notes:

A) Attachment of the Converter

The following procedure is recommended for mounting the converter for optimum cooling and to circumvent any potential damage to the converter.

Ensure that flatness of the plate where M3GB converter to be mounted is no greater than 0.003" per linear inch. It is recommended that a thermally conductive gasket is used to promote the thermal transfer and to fill any voids existing between the two surfaces. IR HiRel recommends Sil-Pad 2000 with the thickness of 0.010". The shape of the gasket should match the footprint of the converter including the mounting flanges. The gasket is available from IR HiRel. The M3GB-Series converter requires either M3 or 4-40 size screws for attachment purposes

The procedure for mounting the converter is as follows:

1. Check the mounting surfaces and remove foreign material, burrs if any or anything that may interfere with the attachment of the converter.
2. Place the gasket on the surface reserved for the converter and line it up with the mounting holes.
3. Place the converter on the gasket and line both up with mounting holes.
4. Install screws using appropriate washers and tighten by hand (~ 4 in·oz) in the sequence shown below.

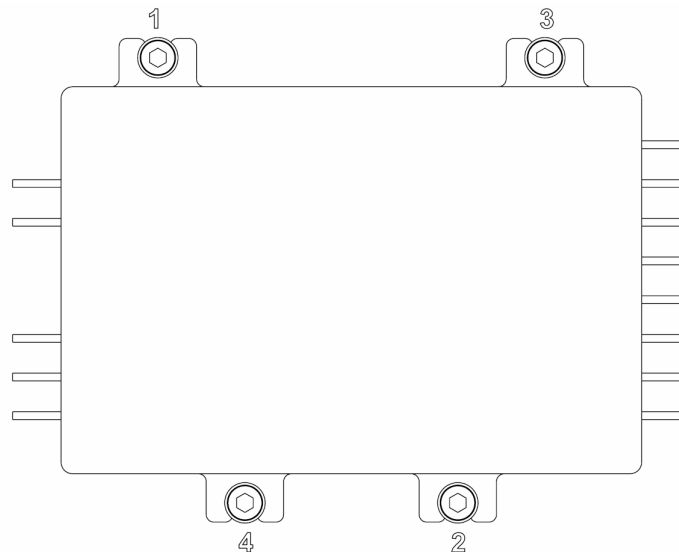

5. Tighten the screws with an appropriate torque driver. Torque the screws up to 6 in·lb in the sequence shown above.

B) Output Voltage Adjustment

To adjust the output voltage, a resistor (R_{ADJ}) is connected between the Adjust pin (Pin 8) and either the Main Return or Main Out pins depending on whether the output voltage is to be adjusted higher or lower than the nominal set-point. This allows the outputs to be reliably adjusted by approximately +4.8% to -1.5% of the nominal output voltage. Refer to Fig. 2 and use equations provided to calculate the required resistance (R_{ADJ}). Please note that the auxiliary output voltages will track the voltage of the main output, higher or lower than the set points by the same percentage of adjustment.

Fig 2. Configuration for Adjusting Triple Output Voltage

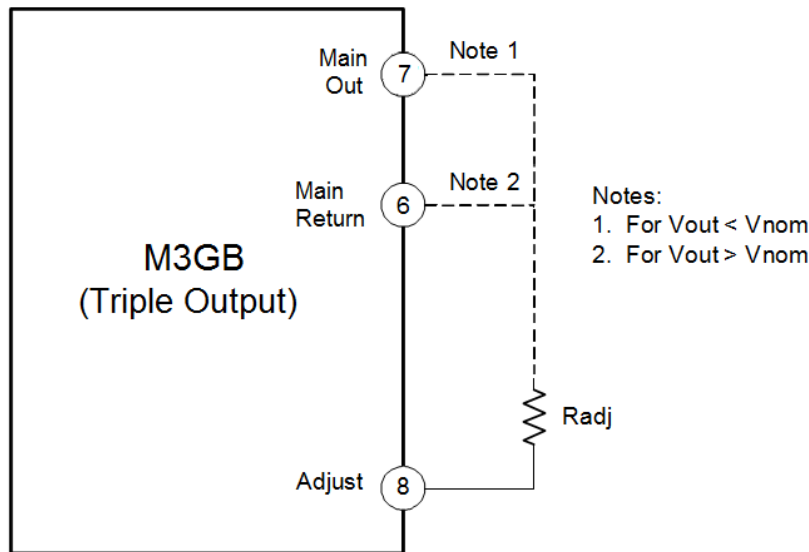

For **all Triple Output Models**, to adjust the output voltages higher:

$$R_{ADJ} = \frac{10 \times (V_{NOM} - 2.5)}{V_{OUT} - V_{NOM}} - 50$$

Where: R_{ADJ} is in kOhms
 R_{ADJ} is connected to the -Out pin and $3.3 < V_{OUT} < 3.46$ (Fig. 2, Note 2)
 V_{NOM} is the nominal output voltage with the Adjust Pin left open
 V_{OUT} is the desired output voltage

For **all Triple Output Models**, to adjust the output voltages lower:

$$R_{ADJ} = \frac{4 \times (V_{NOM} - 2.5) \times (V_{OUT} - 2.5)}{V_{NOM} - V_{OUT}} - 50$$

Where: R_{ADJ} is in kOhms
 R_{ADJ} is connected to the +Out pin and $3.25 < V_{OUT} < 3.3$ (Fig. 2, Note 1)
 V_{NOM} is the nominal output voltage with the Adjust Pin left open
 V_{OUT} is the desired output voltage

Mechanical Outline

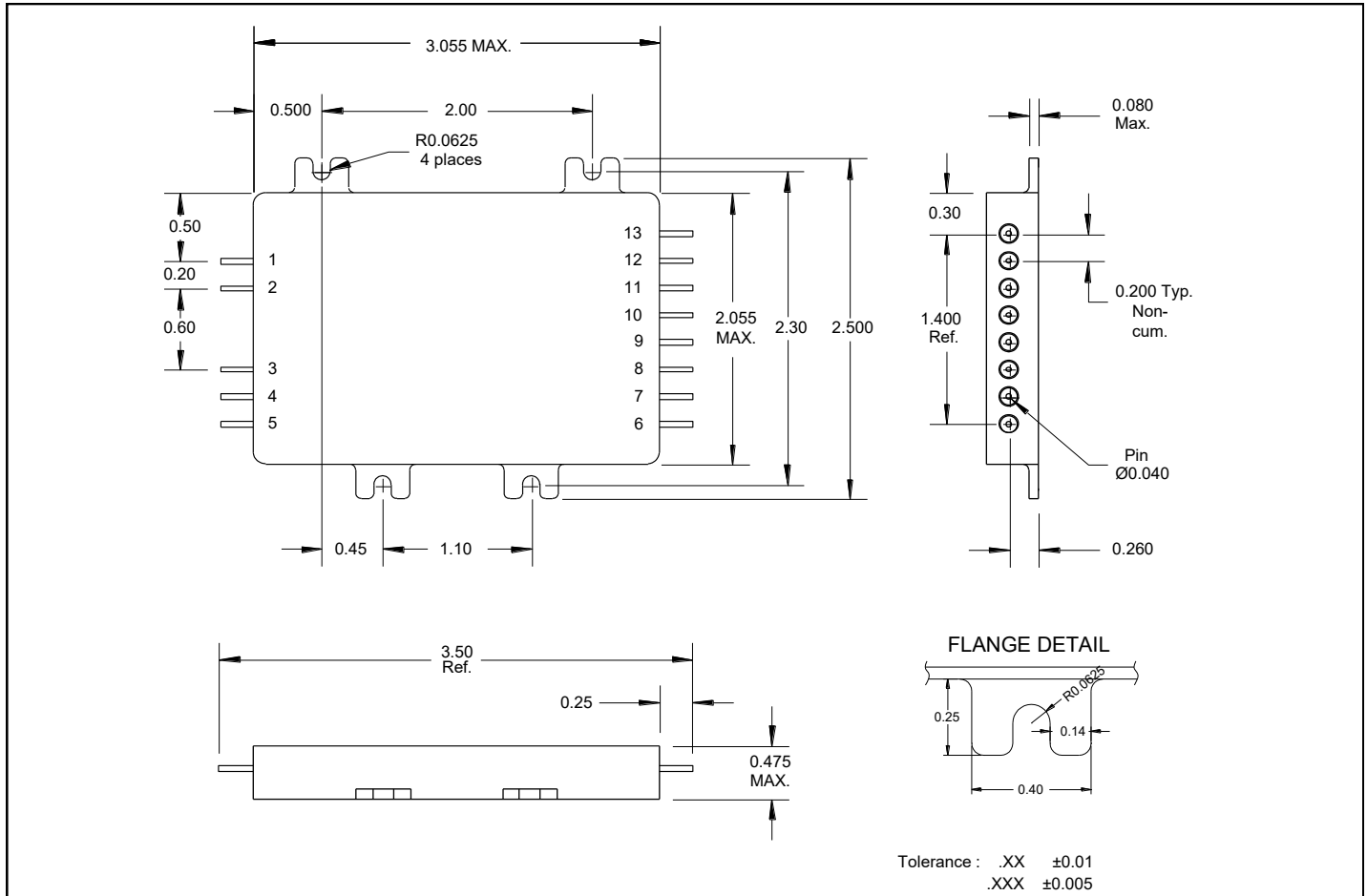

Pin Designation

Pin #	Designation	Pin #	Designation
1	VIN	8	VADJ
2	RETURN	9	NC
3	INHIBIT	10	CASE GROUND
4	SYNC. INPUT	11	- AUX. OUTPUT
5	SYNC. OUTPUT	12	AUX. OUTPUT RETURN
6	MAIN RETURN	13	+ AUX. OUTPUT
7	+ MAIN OUTPUT		

Device Screening

Part Number Designator		/EM ①	/CK ②
Compliance Level	MIL-PRF-38534	—	K level compliant
Certification Mark		—	CK
Screening Requirement	MIL-STD-883 Method	—	—
Temperature Range	—	Room Temperature	-55°C to +85°C
Element Evaluation	MIL-PRF-38534	N/A	Class K
Non-Destructive Bond Pull	2023	N/A	Yes
Internal Visual	2017	IR Defined	Yes
Temperature Cycle	1010	N/A	Cond C
Constant Acceleration	2001, Y1 Axis	N/A	3000 Gs
PIND	2020	N/A	Cond A
Burn-In	1015	N/A	320 hrs @ 125°C (2 x 160 hrs)
Final Electrical (Group A)	MIL-PRF-38534 & Specification	Room Temperature	-55°C, +25°C, +85°C
PDA	MIL-PRF-38534	N/A	2%
Seal, Fine and Gross	1014	N/A	Cond CH
Radiographic	2012	N/A	Yes
External Visual	2009	IR Defined	Yes

Notes:

- ① **"EM" grade** parts are strictly intended to permit the customer to determine the electrical functionality of the device in the customer's application in ambient conditions. The use of EM devices in production applications presents an unquantifiable risk of failure and IR HiRel disclaims all responsibility for such failure.
- ② **"CK" grade** is the flight model (FM) compliant to K Level screening as defined in the DLA Land and Maritime MIL-PRF-38534 requirements, but is not necessarily a DLA Land and Maritime qualified SMD per MIL-PRF-38534. The governing document for this part number designator is the IR HiRel datasheet (this document). Radiation rating as stated in the "Radiation Performance Characteristics" section, is verified by analysis and test per IR HiRel internal procedure. The part is marked with the IR base part number and the "CK" certification mark.

Part Numbering

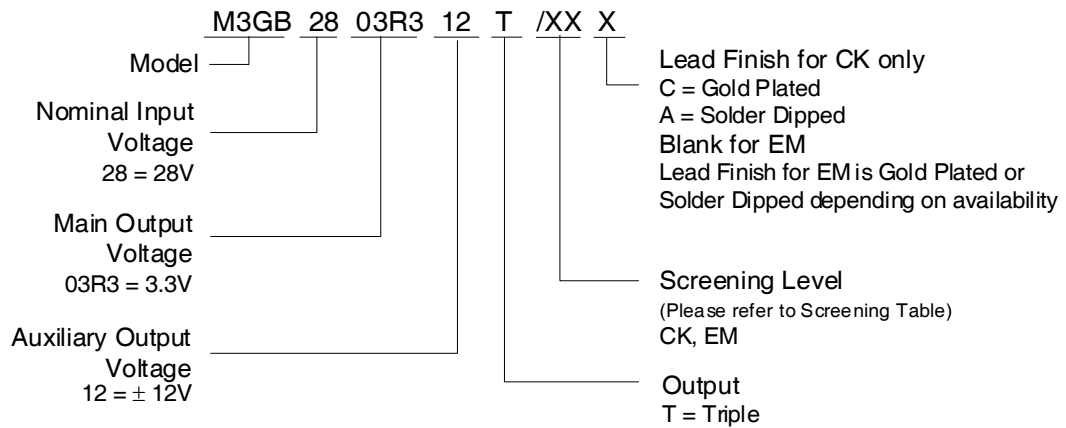

IMPORTANT NOTICE

The information given in this document shall be in no event regarded as guarantee of conditions or characteristic. The data contained herein is a characterization of the component based on internal standards and is intended to demonstrate and provide guidance for typical part performance. It will require further evaluation, qualification and analysis to determine suitability in the application environment to confirm compliance to your system requirements.

With respect to any example hints or any typical values stated herein and/or any information regarding the application of the product, Infineon Technologies hereby disclaims any and all warranties and liabilities of any kind including without limitation warranties on non-infringement of intellectual property rights and any third party.

In addition, any information given in this document is subject to customer's compliance with its obligations stated in this document and any applicable legal requirements, norms and standards concerning customer's product and any use of the product of Infineon Technologies in customer's applications.

The data contained in this document is exclusively intended for technically trained staff. It is the responsibility of any customer's technical departments to evaluate the suitability of the product for the intended applications and the completeness of the product information given in this document with respect to applications.

For further information on the product, technology, delivery terms and conditions and prices, please contact your local sales representative or go to (www.infineon.com/irhirel).

WARNING

Due to technical requirements products may contain dangerous substances. For information on the types in question, please contact your nearest Infineon Technologies office.