

HYBRID-HIGH RELIABILITY RADIATION HARDENED DC-DC CONVERTER

100V Input, Single Output

Description

The GHP10006S is a customized version of DC-DC converters are radiation hardened, high reliability converters specifically designed in response to the need for moderate power, high efficiency and well regulated output required by the modern day space design applications. Their small size and low weight make them ideal for applications such as geostationary earth orbit satellites and deep space probes. They exhibit a high tolerance to total ionizing dose, single event effects and environmental stresses such as temperature extremes, mechanical shock, and vibration.

The converters incorporate a fixed frequency single ended forward topology with magnetic feedback and an internal EMI filter that utilizes multilayer ceramic capacitors that are subjected to extensive lot screening for optimum reliability. By using two stage filtering these converters produce low input and output noise. External inhibit and synchronization input and output allow these converters to be easily incorporated into larger power systems. They are enclosed in a hermetic 3"x2"x0.475" package constructed of an Aluminum-Silicon-Carbide (AlSiC) base and an Alloy 48 ring frame and they weigh less than 110 grams. The package utilizes rugged ceramic feed-through copper core pins and is sealed using parallel seam welding.

Manufactured in a facility fully qualified to MIL-PRF-38534, these converters are fabricated utilizing DLA Land and Maritime qualified processes. For available screening options, refer to device screening table in the data sheet.

Non-flight versions of the GHP-Series converters are available for system development purposes. Variations in electrical specifications and screening to meet custom requirements can be accommodated.

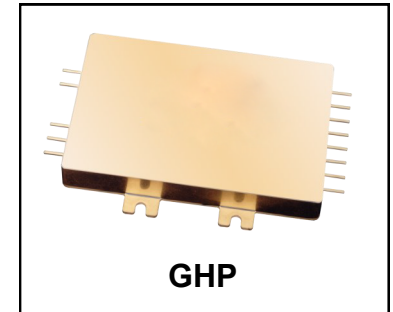

Features

- Total Dose > 100 kRads(Si)
- SEE Hardened to LET up to 82 MeV·cm²/mg
- Low Weight < 110 grams
- Low Input & Output Noise
- Magnetically Coupled Feedback
- 65V to 110V DC Input Range
- Up to 96W Output Power
- 6V Single Output
- High Efficiency to 83%
- -55°C to +125°C Operating Temperature Range
- 100MΩ @ 500VDC Isolation
- Under-Voltage Lockout
- Short Circuit and Overload Protection
- Adjustable Output with an External Resistor
- Remote Sense on Single Output Models
- Synchronization Input and Output
- External Inhibit
- > 3.3 Million Hours MTBF

Applications

- Geostationary Earth Orbit Satellites (GEO)
- Deep Space Satellites / Probes
- Strategic Weapons and Communication System

Specifications

Absolute Maximum Ratings		Recommended Operating Conditions	
Input Voltage	-0.5V _{DC} to +120V _{DC}	Input Voltage	+65V _{DC} to +110V _{DC}
Output power	Internally limited	Output power	0 to Max. Rated
Lead Temperature	+300°C for 10 seconds	Operating temperature	-55°C to +85°C
Operating temperature	-55°C to +125°C	Operating temperature ¹	-55°C to +70°C
Storage temperature	-55°C to +125°C		

¹ For operation at +125°C, see table, note10

Electrical Performance Characteristics

Parameter	Group A Subgroup	Conditions -55°C ≤ T _C ≤ +85°C V _{IN} = 100V DC ± 5%, C _L = 0 unless otherwise specified	Limits			Unit
			Min	Nom	Max	
Input voltage (V _{IN})			65	100	110	V
Output voltage (V _{OUT})	1	I _{OUT} = 100% rated load	5.87	6.00	6.03	V
	2,3		5.91			
Output power (P _{OUT})	1,2,3	V _{IN} = 65, 100, 110 Volts, Note 2	0		96	W
Output current (I _{OUT})	1,2,3	V _{IN} = 65, 100, 110 Volts, Note 2	0		16	A
Line regulation (VR _{LINE})	1,2,3	V _{IN} = 65, 100, 110 Volts I _{OUT} = 0, 50%, 100% rated	-10		10	mV
Load regulation (VR _{LOAD})	1,2,3	I _{OUT} = 0, 50%, 100% rated V _{IN} = 65, 100, 110 Volts	-0.5		0.5	%
Total regulation (Line, Load, and Temperature)	1,2,3	V _{IN} = 65, 100, 110 Volts I _{OUT} = 0, 50%, 100% rated, Note 11	-2.0		2.0	%
Input current (I _{IN})	1,2,3	I _{OUT} = 0, Pin 3 open Pin 3 shorted to Pin 2		70	100	mA
				2.5	5.0	
Output ripple (V _{RIP}) GHP10006S	1,2,3	V _{IN} = 65, 100, 110 Volts I _{OUT} = 100% rated load Note 3		15	50	mVp-p
Input ripple current	1,2,3	I _{OUT} = 100% rated load		7.0	18	mArms
Switching frequency (F _S)	1,2,3	Sync. Input (Pin 4) open	450	500	550	kHz
Efficiency (E _{FF})	1,2,3	I _{OUT} = 100% rated load	79	83		%

For Notes to Electrical Performance Characteristics, refer to page 4

Electrical Performance Characteristics (continued)

Parameter	Group A Subgroup	Conditions -55°C ≤ T _C ≤ +85°C V _{IN} = 100V DC ± 5%, C _L = 0 unless otherwise specified	Limits			Unit
			Min	Nom	Max	
Inhibit Input Converter Off Sink current Converter On Sink current	1, 2, 3	Logic Low on Pin 3 Note 1 Logic High on Pin 3 Note 1	-0.5 2.0		0.8 100 50 100	V μA V μA
Synchronization Input frequency range pulse high level pulse low level pulse transition time pulse duty cycle		Ext. Clock on Sync. Input (Pin 4) Note 1	450 4.0 -0.5 40 20		600 10 0.5 80	kHz V V V/μs %
Current Limit Point Expressed as a percentage of full rated load current	1,2,3	V _{OUT} = 90% of Nominal			145	%
Power dissipation, load fault (P _D)	1,2,3	Short Circuit, Overload, Note 5			35	W
Output response to step load changes (V _{TL D})	4,5,6	Half Load to/from Full Load, Note 6	-300		+300	mVpk
Recovery time, step load changes (T _{TL D})	4, 5, 6	Half Load to/from Full Load, Notes 6, 7			200	μs
Output response to step line changes (V _{TL N})		65V to/from 110V I _{OUT} = 100% rated load, Note 8	-150		150	mVpk
Recovery time, step line changes (T _{TL N})		65V to/from 110V I _{OUT} = 100% rated load, Notes 7,8			200	μs
Capacitive load (C _L)		I _{OUT} = 100% rated load No effect on DC performance Notes 1, 4			3000	μF
Turn-on Response Overshoot (V _{OS}) Turn-on Delay (T _{DLY})	4,5,6	No Load, Full Load Notes 9	1.0		2.0 5.0	% ms
Line Rejection		I _{OUT} = 100% rated load DC to 50 kHz, Note 1	40	60		dB
Isolation	1	Input to Output or Any Pin to Case except Pin 6, test @ 500VDC	100			MΩ
Device Weight					110	g
MTBF		MIL-HDBK-217F2, SF, 35°C	3.3x10 ⁶			Hrs

For Notes to Electrical Performance Characteristics, refer to page 4

Notes: Electrical Performance Characteristics Table

1. Parameter is tested as part of design characterization or after design changes. Thereafter, parameter shall be guaranteed to the limits specified.
2. Parameter verified during line and load regulation tests.
3. Guaranteed for a DC to 20MHz bandwidth. Tested using a 20kHz to 10MHz bandwidth.
4. Capacitive load may be any value from 0 to the maximum limit without compromising dc performance. A capacitive load in excess of the maximum limit may interfere with the proper operation of the converter's overload protection, causing erratic behavior during turn-on.
5. Overload power dissipation is defined as the device power dissipation with the load set such that $V_{OUT} = 90\%$ of nominal.
6. Load step transition time $\geq 10 \mu s$.
7. Recovery time is measured from the initiation of the transient to where V_{OUT} has returned to within $\pm 1\%$ of its steady state value.
8. Line step transition time $\geq 100 \mu s$.
9. Turn-on delay time from either a step application of input power or a logic low to a logic high transition on the inhibit pin (pin 3) to the point where $V_{OUT} = 90\%$ of nominal.
10. Although operation at temperatures between $+85^{\circ}C$ and $+125^{\circ}C$ is guaranteed, no parametric limits are specified.
11. The total regulation at EOL is $\pm 3\%$ maximum.

Radiation Performance Characteristics

Test	Conditions	Min	Typ	Unit
Total Ionizing Dose (Gamma)	MIL-STD-883, Method 1019 Operating bias applied during exposure Full Rated Load, $V_{IN} = 100V$	100	150	kRads (Si)
Single Event Effects SEU, SEL, SEGR, SEB	Heavy ions (LET) Operating bias applied during exposure, Full Rated Load. $V_{IN} = 65V, 100V, 110V$ Test Lab: Texas A & M University	82		$MeV \cdot cm^2 / mg$

Fig 1. Block Diagram - Single Output

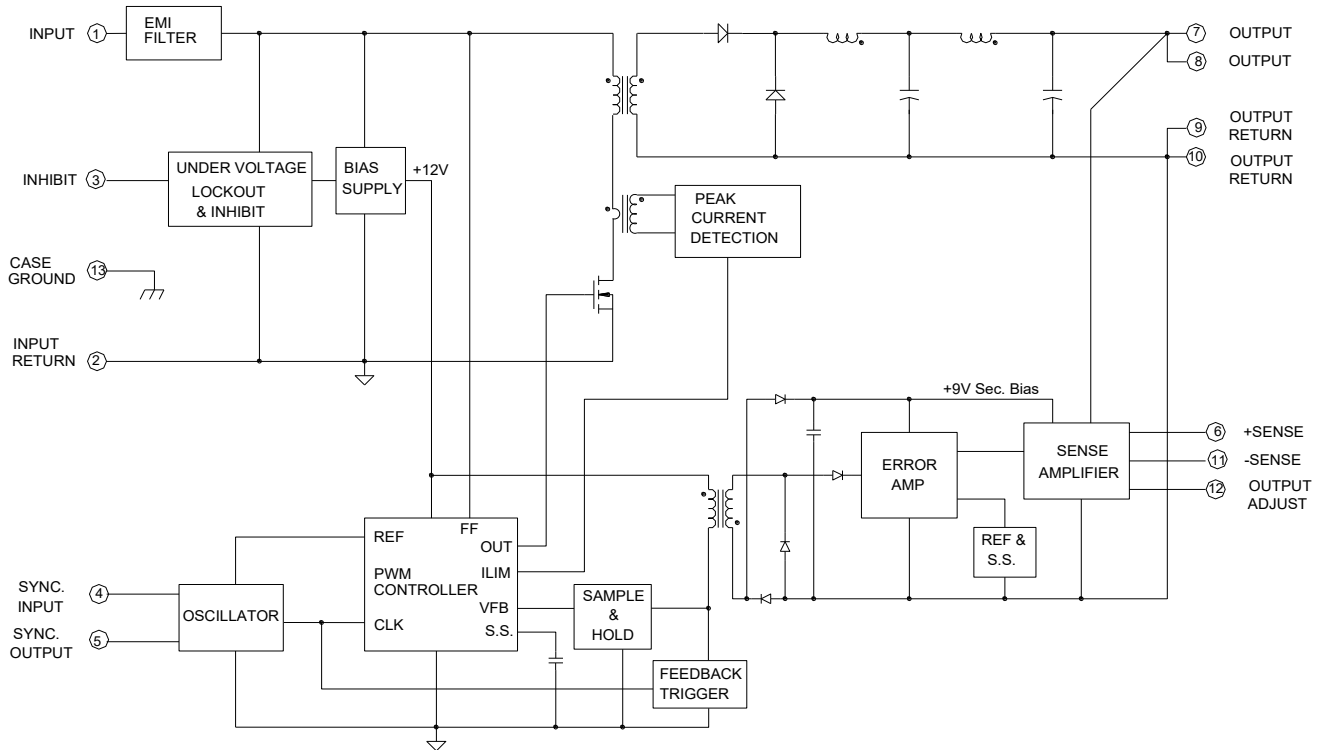

Application Notes:

A) Attachment of the Converter

The following procedure is recommended for mounting the converter for optimum cooling and to circumvent any potential damage to the converter.

Ensure that flatness of the plate where GHP converter to be mounted is no greater than 0.003" per linear inch. It is recommended that a thermally conductive gasket is used to promote the thermal transfer and to fill any voids existing between the two surfaces. HiRel recommends Sil-Pad 2000 with the thickness of 0.010". The shape of the gasket should match the footprint of the converter including the mounting flanges. The gasket is available from IR HiRel. The GHP-Series converter requires either M3 or 4-40 size screws for attachment purposes.

The procedure for mounting the converter is as follows:

1. Check all mounting surfaces and remove foreign material, burrs, if any or anything that may interfere with the attachment of the converter.
2. Place the gasket on the surface reserved for the converter and line it up with the mounting holes.
3. Place the converter on the gasket and line both up with mounting holes.
4. Install screws using appropriate washers and tighten by hand (~ 4 in·oz) in the sequence shown below.

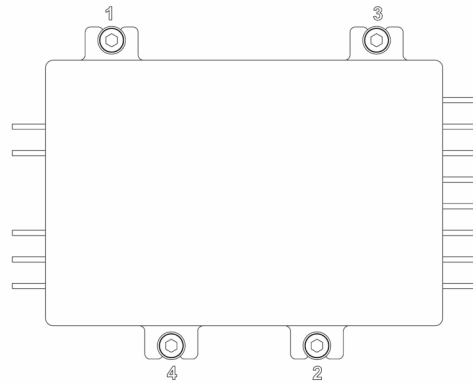

5. Tighten the screws with an appropriate torque driver. Torque the screws up to 6 in·lb in the sequence shown above.

B) Output Voltage Adjustment.

Single Output:

To adjust the output voltage of the single output models, a resistor (R_{ADJ}) is connected between the Adjust pin (Pin 12) and either the positive or negative remote sense pins, depending on whether the output voltage is to be adjusted higher or lower than the nominal set-point. This allows the outputs to be reliably adjusted by approximately +10% to -20% of the nominal output voltage. Refer to Fig. 3 and use equations provided to calculate the required resistance (R_{ADJ}).

Note: The output voltage adjust equation does not work as described for the 3.3V Single model. The adjust range for 3.3V model is limited to 3.252V to 3.460V.

Fig 3. Configuration for Adjusting Single Output Voltage

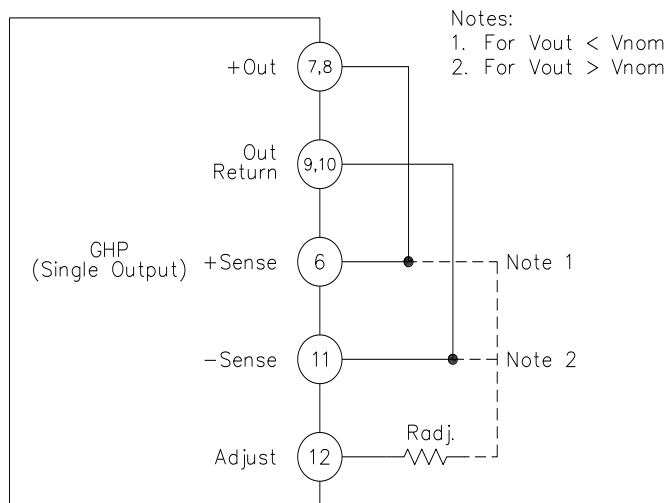

For **all Single Output Models**, to adjust the output voltages higher:

$$R_{ADJ} = \frac{10 \times (V_{NOM} - 2.5)}{V_{OUT} - V_{NOM}} - 50$$

Where: R_{ADJ} is in kOhms

R_{ADJ} is connected to the -Out pin and $V_{NOM} < V_{OUT} < 1.1V_{NOM}$ (Fig. 3, Note 2)

V_{NOM} is the nominal output voltage with the Adjust pin left open

V_{OUT} is the desired output voltage

For **all Single Output Models**, to adjust the output voltages lower:

$$R_{ADJ} = \frac{4 \times (V_{NOM} - 2.5) \times (V_{OUT} - 2.5)}{V_{NOM} - V_{OUT}} - 50$$

Where: R_{ADJ} is in kOhms

R_{ADJ} is connected to the +Out pin and $0.8V_{NOM} < V_{OUT} < V_{NOM}$ (Fig. 3, Note 1)

V_{NOM} is the nominal output voltage with the Adjust pin left open

V_{OUT} is the desired output voltage

Mechanical Outline

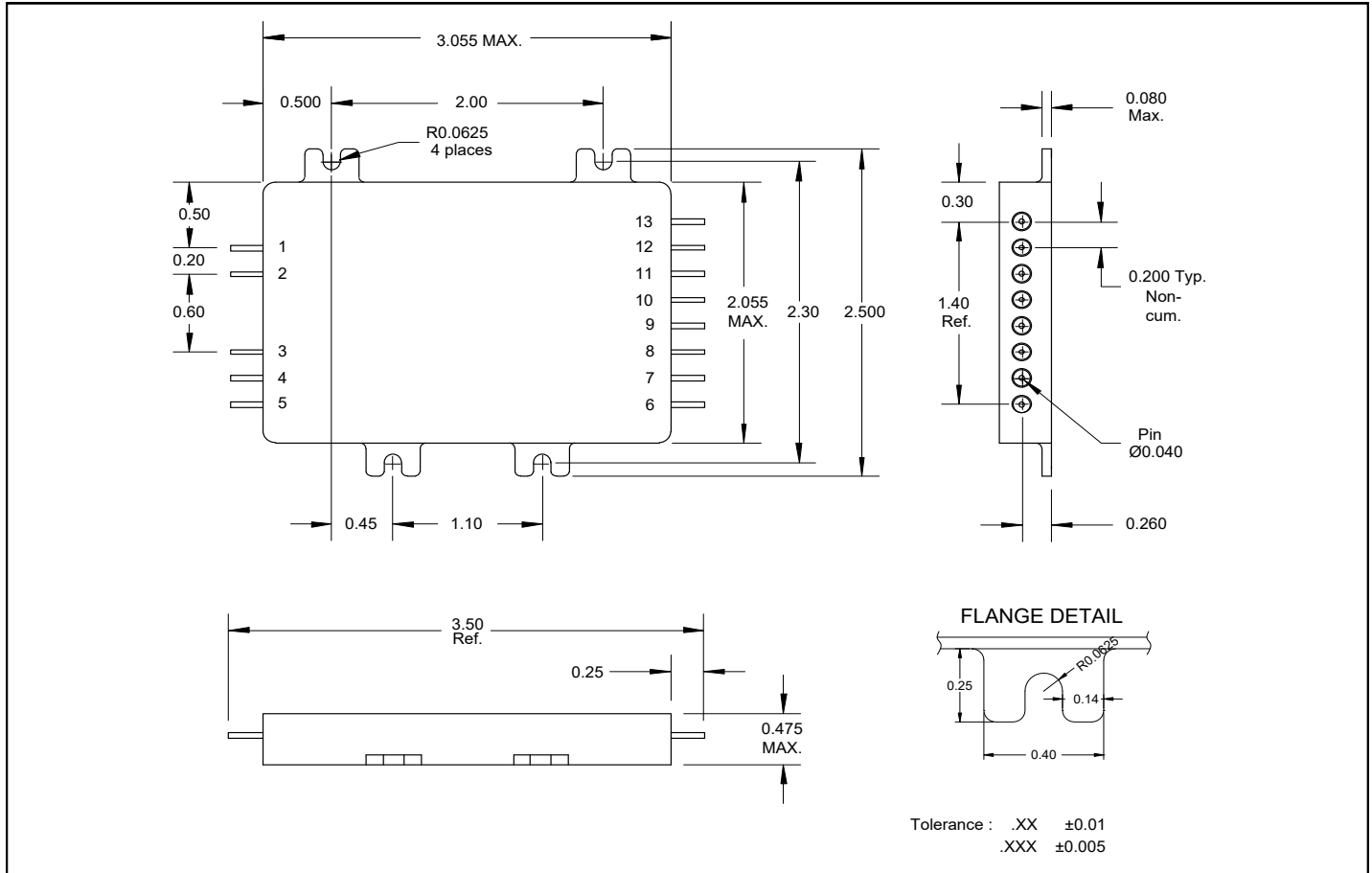

Pin Designation

Single Output	
Pin #	Designation
1	Input
2	Input Return
3	Inhibit
4	Sync. Input
5	Sync. Output
6	+ Sense
7	Output
8	Output
9	Output Return
10	Output Return
11	- Sense
12	Output Adjust
13	Case Ground

Device Screening

Part Number Designator		/EM ①	/CK ②
Compliance Level	MIL-PRF-38534	—	K level compliant
Certification Mark		—	CK
Screening Requirement	MIL-STD-883 Method	—	—
Temperature Range	—	Room Temperature	-55°C to +85°C
Element Evaluation	MIL-PRF-38534	N/A	Class K
Non-Destructive Bond Pull	2023	N/A	Yes
Internal Visual	2017	IR Defined	Yes
Temperature Cycle	1010	N/A	Cond C
Constant Acceleration	2001, Y1 Axis	N/A	3000 Gs
PIND	2020	N/A	Cond A
Burn-In	1015	N/A	320 hrs @ 125°C (2 x 160 hrs)
Final Electrical (Group A)	MIL-PRF-38534 & Specification	Room Temperature	-55°C, +25°C, +85°C
PDA	MIL-PRF-38534	N/A	2%
Seal, Fine and Gross	1014	N/A	Cond CH
Radiographic	2012	N/A	Yes
External Visual	2009	IR Defined	Yes

Notes:

- ① **"EM" grade** parts are strictly intended to permit the customer to determine the electrical functionality of the device in the customer's application in ambient conditions. The use of EM devices in production applications presents an unquantifiable risk of failure and IR HiRel disclaims all responsibility for such failure.
- ② **"CK" grade** is the flight model (FM) compliant to K Level screening as defined in the DLA Land and Maritime MIL-PRF-38534 requirements, but is not necessarily a DLA Land and Maritime qualified SMD per MIL-PRF-38534. The governing document for this part number designator is the IR HiRel datasheet (this document). Radiation rating as stated in the "Radiation Performance Characteristics" section, is verified by analysis and test per IR HiRel internal procedure. The part is marked with the IR base part number and the "CK" certification mark.

Part Numbering

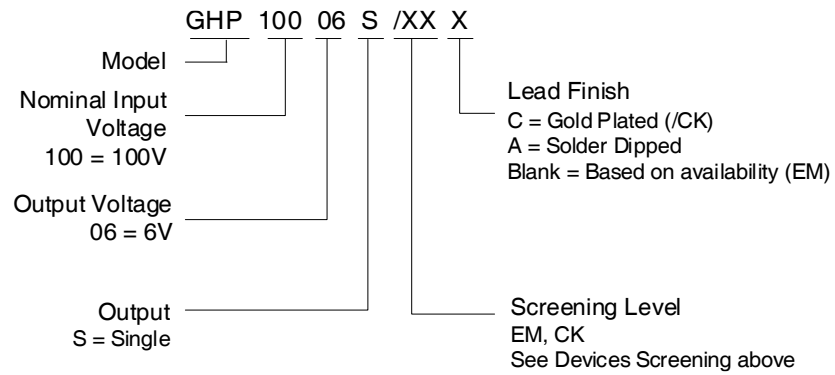

one source. one solution.®

www.micross.com

Americas: 1.855.426.6766

EMEA & APAC: +44 (0) 1603.788967

China: +85 21.5459.1970

India: +91 7760.990.545

Micross Components reserves the right to change products or specifications without notice.