

**HIGH RELIABILITY
RADIATION HARDENED
LOW POWER
DC-DC CONVERTER**

28V Input, 5W Single Output

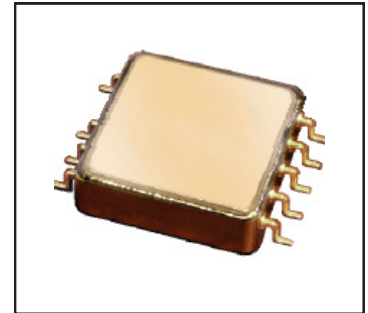

Description

The ARA Series of DC-DC converters are low power radiation hardened, high reliability devices designed for radiation environments such as those encountered by geostationary earth orbit satellites, deep space probes and communication systems. Features include small size, high efficiency, low weight and a high tolerance to total ionizing dose, single event effects and environmental stresses such as temperature extremes, mechanical shock, and vibration. Extensive documentation including Radiation Test report, Thermal Analysis, Stress Analysis and MTBF are available.

The ARA Series converters incorporate a fixed frequency fly back topology with magnetic feedback. All models include an external inhibit port. They are encased in a hermetic 1.075" x 1.075" x 0.31" AISi package and weigh less than 13 grams. The package utilizes rugged ceramic feed-through copper core pins and is hermetically sealed using laser welding.

Environmental screening includes temperature cycling, constant acceleration, fine and gross leak, and burn-in as specified by MIL-PRF-38534 for class K hybrids.

Non-flight versions of the ARA Series converters are available for system development purposes. Variations in electrical specifications and screening to meet custom requirements can be accommodated.

Features

- Total Dose Guaranteed to 100 kRads(Si)
- SEE with LET up to 82 MeV.cm²/mg
- Low Weight < 13 grams
- Magnetically Coupled Feedback
- 18V to 50V DC Input Range
- Up to 5W Output Power
- 3.3V, 5V, 12V, 15V Single Output Models
- Low Quiescent Current
- High Efficiency - to 80%
- -55°C to +85°C Operating Temperature Range
- 100MΩ @ 100V DC Isolation
- Under-Voltage Lockout
- Short Circuit and Overload Protection
- External Inhibit
- Output Adjustment / Remote Sense

Applications

- Geostationary Earth Orbit Satellites (GEO)
- Deep Space Satellites / Probes
- Strategic Weapons and Communication System

Circuit Description

The ARA Series converters utilize a fly back topology with a nominal switching frequency of 400 kHz. Electrical isolation and tight output regulation are achieved through the use of a magnetically coupled feedback.

Output current is limited under any load fault condition to approximately 165% of rated. The converter will resume normal operation when the load current is reduced below the current limit point. This protects the converter from both overload and short circuit conditions. There are no latching elements included in the load fault protection circuits to eliminate the possibility of falsely triggering the protection circuits during single event radiation exposure.

An under-voltage lockout circuit prohibits the converter from operating when the line voltage is too low to maintain the output voltage. The converter will not start until the line voltage rises to approximately 17 volts and will shut down when the input voltage drops below 16 volts. The hysteresis reduces the possibility of line noise interfering with the converter's start-up and shut down circuitry.

An external inhibit port is provided to control converter operation. The converter's operation is inhibited when this pin is pulled low. It is intended to be driven by an open collector device. The pin may be left open for normal operation and has a nominal open circuit voltage of about 12.75V.

Design Methodology

The ARA Series was developed using a proven conservative design methodology, which includes selecting radiation tolerant, and established reliability components and fully de-rating to the requirements of MIL-STD-975, MIL-STD-1547, and NASA EE-INST-002. Conservative de-rating of the radiation-hardened power MOSFET virtually eliminates the possibility of SEGR and SEB. A magnetic feedback circuit is utilized instead of opto-couplers to minimize temperature, radiation and aging sensitivity. PSPICE was used extensively to predict and optimize circuit performance for both beginning and end-of-life. Thorough design analyses include Worst Case, Stress, Thermal, Failure Modes and Effects (FMEA) and Reliability (MTBF).

Specifications

Absolute Maximum Ratings		Recommended Operating Conditions	
Input Voltage	-0.5V _{DC} to +60V _{DC}	Input Voltage	+18V _{DC} to +50V _{DC}
Output power	Internally limited	Output power	0 to Max. Rated
Lead Temperature	+300°C for 10 seconds		
Operating temperature	-55°C to +125°C	Operating temperature ¹	-55°C to +85°C
Storage temperature	-55°C to +135°C	Operating temperature ²	-55°C to +70°C

¹ Meets de-rating per MIL-STD-1547,NASA EEE-INST-002 when V_{IN} nominal is 28V and V_{IN} worst case is 50V. (Note 10)

² Meets de-rating per MIL-STD-975, when V_{IN} nominal is 28V and V_{IN} worst case is 50V. (Note 10)

Electrical Performance Characteristics: BOL (Beginning of Life)

Parameter	Group A Subgroup Note 12	Conditions -55°C ≤ T _C ≤ +85°C V _{IN} = 28V DC ± 5%, C _L = 0uF unless otherwise specified	Limits			Unit
			Min	Nom	Max	
Input voltage (V _{IN})	1,2,3		18	28	50	V
Output voltage (V _{OUT}) ARA2803R3S ARA2805S ARA2812S ARA2815S	1,2,3 1,2,3 1,2,3 1,2,3	I _{OUT} = 100% Rated load	3.27 4.95 11.88 14.85	3.30 5.00 12.00 15.00	3.33 5.05 12.12 15.15	V
Output power (P _{OUT}) ARA2803R3S All others	1,2,3	V _{IN} = 18, 28, 50 Volts, Note 2	0 0		4.0 5.0	W
Output current (I _{OUT}) ARA2803R3S ARA2805S ARA2812S ARA2815S	1,2,3	V _{IN} = 18, 28, 50 Volts, Note 2	0 0 0 0		1.21 1.0 0.416 0.333	A
Line regulation (VR _{LINE})	1, 4	V _{IN} = 18, 28, 50 Volts I _{OUT} = 0, 50%, 100% Rated	-0.50		0.50	%
Load regulation (VR _{LOAD})	1,2,3 4,5,6	I _{OUT} = 0, 50%, 100% Rated V _{IN} = 18, 28, 50 Volts	-0.50		0.50	%
Total regulation (Line & Load)	1, 4	V _{IN} = 18, 28, 50 Volts, I _{OUT} = 0, 50%, 100% Rated, Note11	-1.0		1.0	%
Input current (I _{IN})	1,2,3	I _{OUT} = 0, Pin 4 open Pin 4 shorted to Pin 2			15 1.5	mA
Switching frequency (F _S)	1,2,3		350	400	475	kHz
Output ripple (V _{RIP}) ARA2803R3S ARA2805S ARA2812S ARA2815S	1,2,3	V _{IN} = 18, 28, 50 Volts I _{OUT} = 100% Rated load Note 3		15 15 15 15	35 50 50 50	mVp-p
Efficiency (E _{FF}) ARA2803R3S ARA2805S ARA2812S ARA2815S	1,2,3	I _{OUT} = 100% Rated load	71 71 76 78	75 75 78 80		%

For Notes to Electrical Performance Characteristics, refer to page 5

Electrical Performance Characteristics (continued)

Parameter	Group A Subgroup Note 12	Conditions -55°C ≤ T _C ≤ +85°C V _{IN} = 28V DC ± 5%, C _L = 0uF unless otherwise specified	Limits			Unit
			Min	Nom	Max	
Enable input (Inhibit function) Open circuit voltage Drive current (sink) Voltage range	1,2,3	Note 1	11 -0.5		14 800 50	V μA V
Current Limit Point Expressed as a percentage of full rated load current	1,2,3	V _{OUT} = 90% of Nominal	120		200	%
Power dissipation, load fault (P _D)	1,2,3	Short Circuit, Overload, Note 5			3.5	W
Under Voltage Threshold Release (On) Lockout (OFF) Hysteresis (UVR-UVLO)	1,2,3		14.5 0.4	1.5	17.5	V
Output response to step load changes (V _{TLD})	4,5,6	Half load to/ from Full load, Note 6	-300		300	mVpk
Recovery time, step load changes (T _{TLD})	4,5,6	Half load to/from Full load, Notes 6, 7			300	μs
Output response to step line changes (V _{TLN})	4,5,6	18V to/from 50V I _{OUT} = 100% Rated load, Notes 1, 8	-300		300	mVpk
Recovery time, step line changes (T _{TLN})	4,5,6	18V to/from 50V I _{OUT} = 100% Rated load, Notes 1, 7, 8			200	μs
Turn-on response Overshoot (V _{OS}) Turn-on Delay (T _{DLY})	4,5,6	No load, Full load Note 9	1.5		500 10	mV ms
Capacitive load (C _L) ARA2803R3S ARA2805S ARA2812S ARA2815S	1,2,3	V _{IN} = 18, 28, 50 Volts I _{OUT} = 100% Rated load Notes 3, 4			1000 700 100 80	μF
Line rejection	1	I _{OUT} = 100% Rated load DC to 50 kHz, Note 1		50		dB
Isolation	1	Input to Output or Any Pin to Case except Pin 1, test @ 100VDC	100			MΩ
Device weight					13	g
MTBF		MIL-HDBK-217F2, SF, 35°C	8.0 x 10 ⁶			Hours

For Notes to Electrical Performance Characteristics, refer to page 5

Notes: Electrical Performance Characteristics

1. Parameter is tested as part of design characterization or after design changes. Thereafter, parameter shall be guaranteed to the limits specified.
2. Parameter verified during line and load regulation tests.
3. Guaranteed for a D.C. to 20 MHz bandwidth. Tested using a 20 kHz to 10 MHz bandwidth.
4. Capacitive load may be any value from 0 to the maximum limit without compromising dc performance.
5. Overload power dissipation is defined as the device power dissipation with the load set such that $V_{OUT} = 90\%$ of nominal
6. Load step transition time $\geq 10 \mu\text{s}$.
7. Recovery time is measured from the initiation of the transient to where V_{OUT} has returned to within $\pm 1\%$ of its steady state value.
8. Line step transition time $\geq 100 \mu\text{s}$.
9. Turn-on delay time from either a step application of input power or a logic low to a logic high transition on the Inhibit pin (Pin 4) to the point where $V_{OUT} = 90\%$ of nominal.
10. For ceramic capacitors with voltage stress less than 10V, derating requirements require minimum 100V rated capacitors. The product will use capacitors with a minimum rating of 16V.
11. Total regulation is $\pm 3\%$ for End-of-Life.
12. The Subgroups (SG) below refer to MIL-PRF-38534 Appendix C, Group A. SG 1 is static test at $+25^{\circ}\text{C}$, SG 2 is static test at $+85^{\circ}\text{C}$, SG 3 is static test at -55°C . SG 4 is dynamic test at $+25^{\circ}\text{C}$, SG 5 is dynamic test at $+85^{\circ}\text{C}$, SG 6 is dynamic test at -55°C .

Radiation Performance Characteristics

Test	Conditions	Min	Typ	Max	Unit
Total Ionizing Dose (TID) (Gamma)	Operating bias applied during exposure, Half Rated Load, $V_{IN} = 28V$ $T_C = +25^{\circ}C$, 14 - 50 Rads/s	100		150	kRads(Si)
Single Event Effects (SEE) SEU, SEL, SEGR, SEB - Note 1	Heavy Ions (LET) Operating bias applied during exposure, Full Rated Load, $V_{IN} = 18V, 28V, 50V$ - Note 2	82			MeV.cm ² /mg

Notes:

1. Output perturbation is less than + 5% / -10% of nominal output voltage.
2. Beam condition: Min LET = 82 MeV.cm²/mg

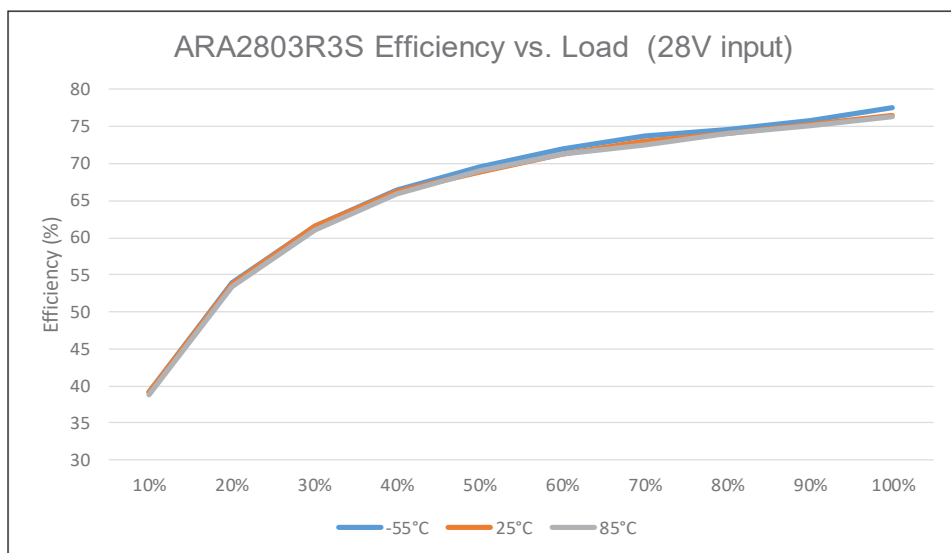
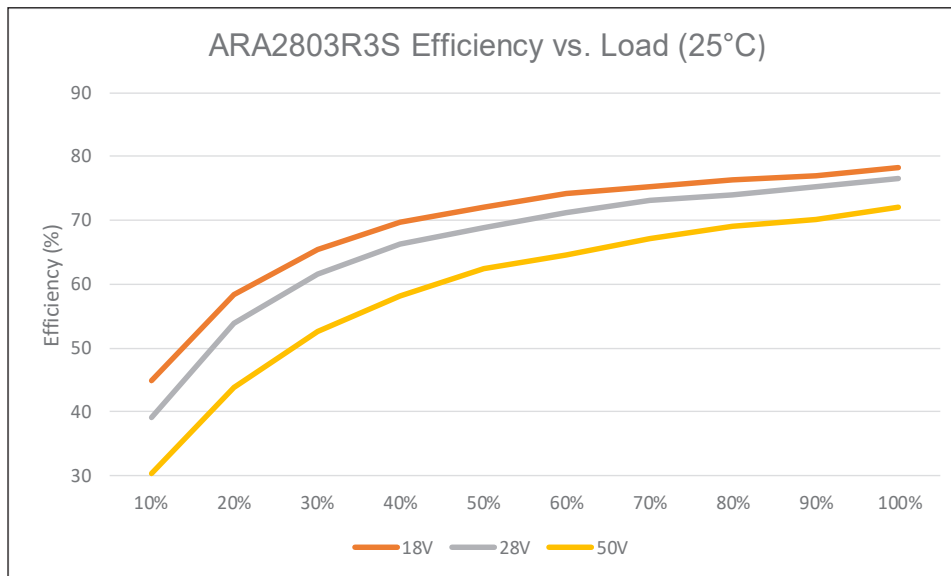
Efficiency Curves :

Efficiency Curves :

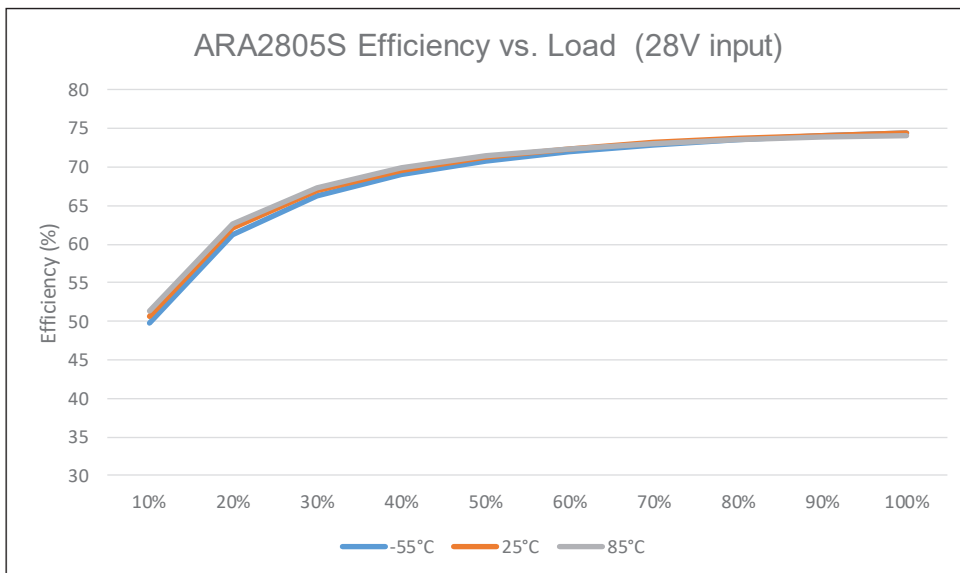
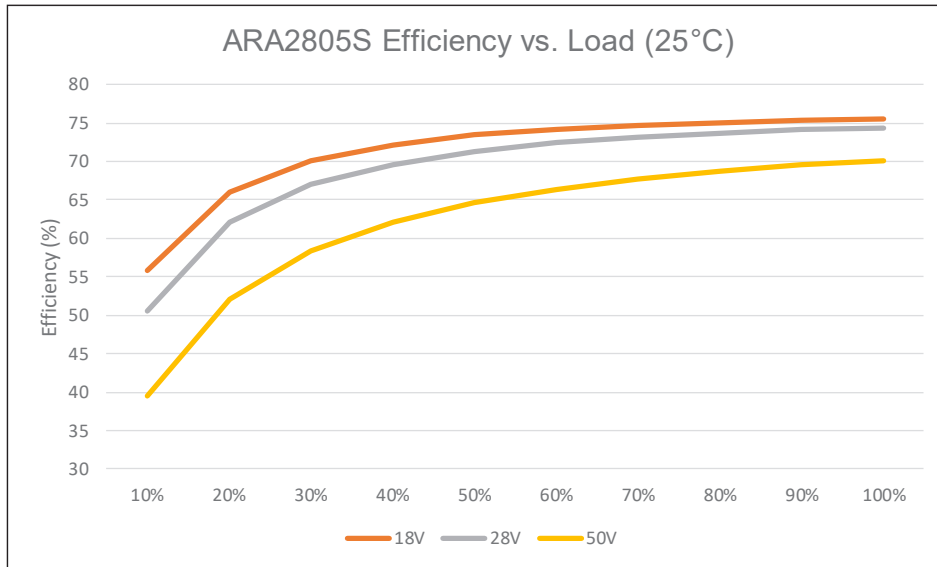

Efficiency Curves :

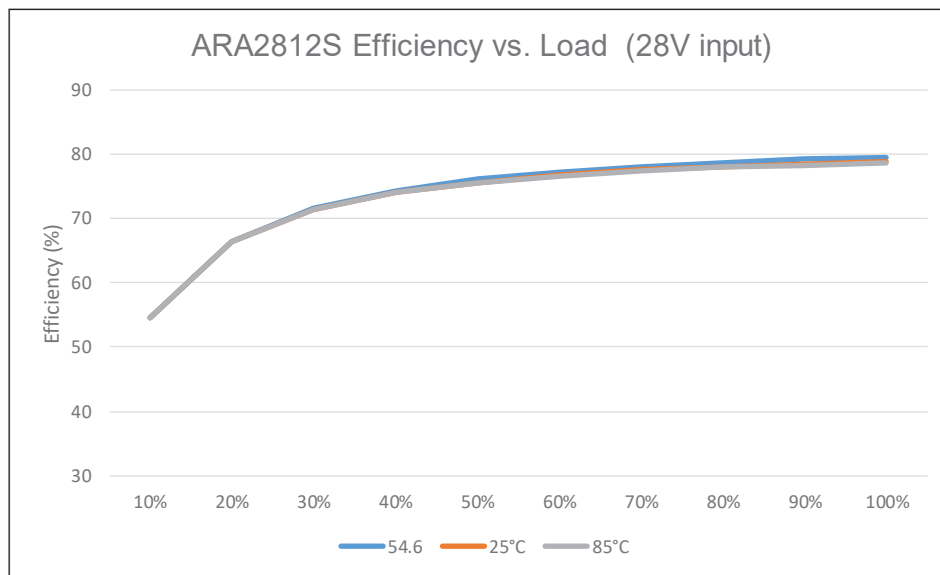
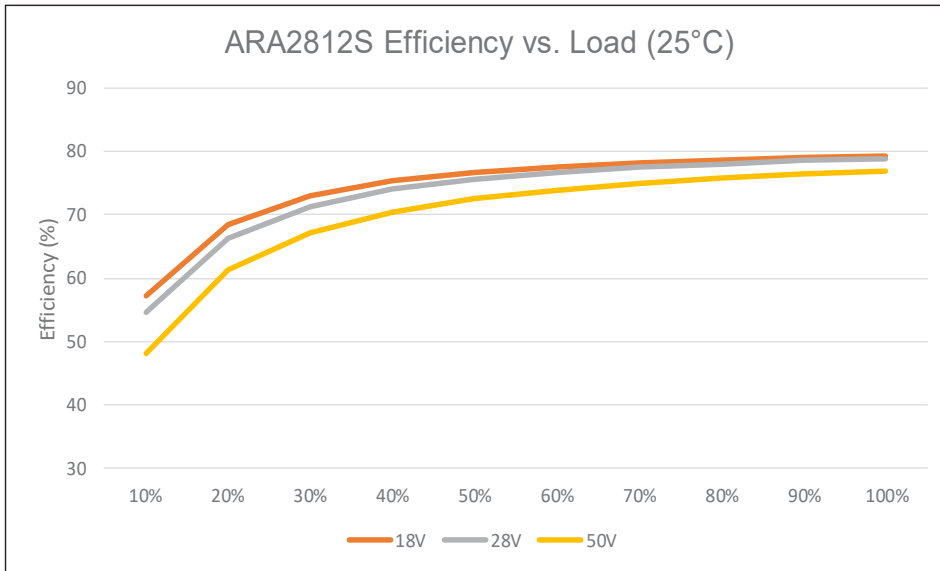

Efficiency Curves :

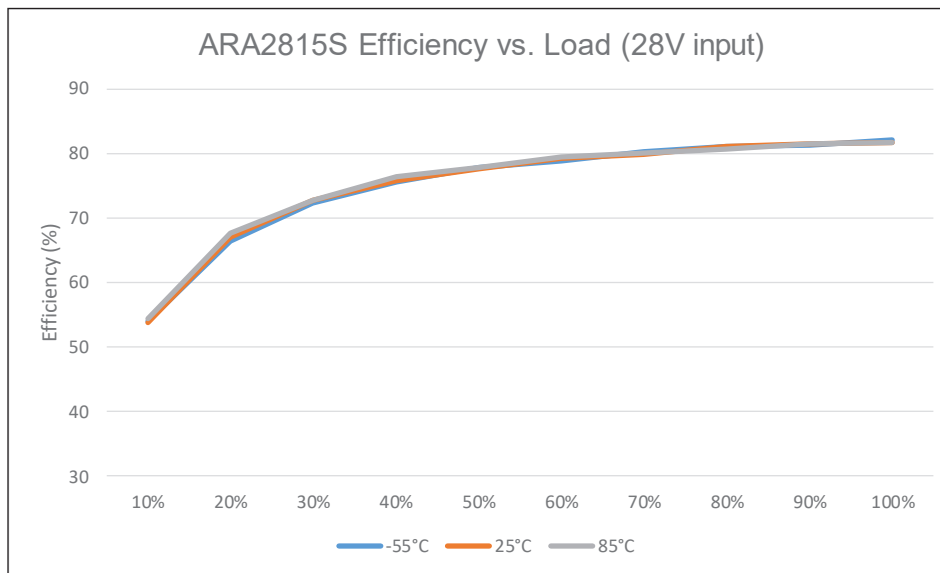
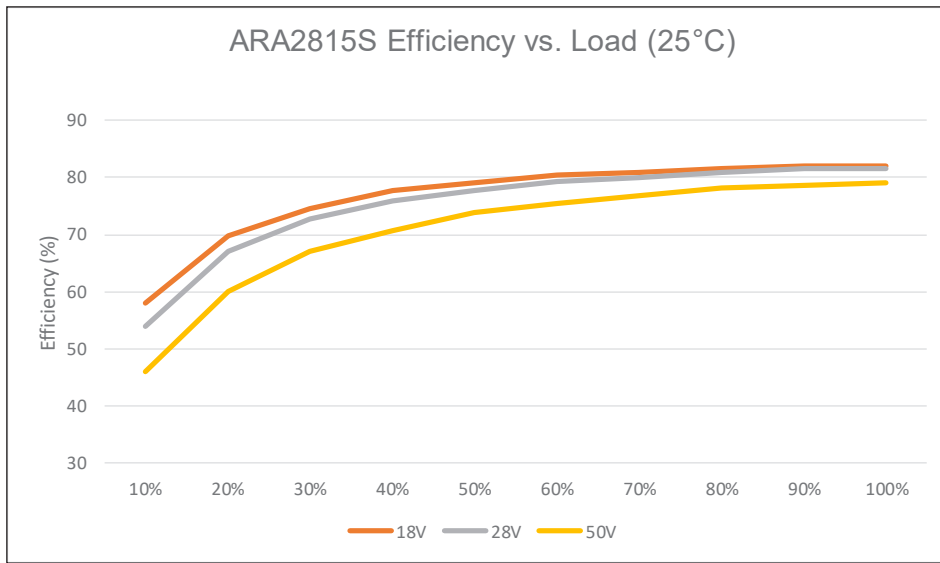

Input Ripple Current:

In the ARA Series converters, as shown in the Block diagram (page 6), there is no series inductor before the input capacitor. Therefore, when measuring the input ripple current it is dependent on the series impedance between the power source and the converter input. The input ripple current measured using a large (1200uF) capacitor connected between the power source and an ARA converter. The capacitor is used to minimize the source impedance supplying the converter. A current probe is connected to measure the current between the converter and the large capacitor. The inductance between the capacitor and the converter is about 400nH. With the given set-up, the input ripple current measures about 300mA peak-to-peak. In order to reduce the input ripple current, an inductor or preferably an AF28461 filter may be used between the source voltage and the ARA Series converters.

Output Voltage Adjustment:

The output of ARA series converters can be adjusted to be greater or less than the nominal output voltage with an external resistor. the ranges of the output voltages are limited depending on the model as specified in Table 1. An approximate value of the resistor can be determined using the following formula.

$$\text{For Single Output Model: } R_{adj} = [A - (B \times V_{out})] / [(C \times V_{out}) - D]$$

Where:

R_{adj} is the value of the external resistor in ohms and is connected as specified in Table 1. Power rating of the resistor shall be greater than 0.125W. A Metal film resistor with temperature coefficient a of less than ±50 ppm and tolerance of less than 1% is recommended. However, the final selection is dependent on specific design requirements.

V_{out} is the desired output voltage in volts.

A, B, C, and D are unique constants depending on the model as shown in Table 1.

Table 1: Single Output Voltage Ranges, Constants and Resistor connection by Model

Model	Output Voltage Range	R _{adj} connection between	A	B	C	D
ARA2803R3S	3.3 to 3.6	Pin 7 & Pin 5	415.0E+6	100.0E+6	10.0E+3	33.3E+3
ARA2805S	5.0 to 5.5	Pin 7 & Pin 5	1.8E+9	316.0E+6	10.0E+3	50.0E+3
	4.5 to 5.0	Pin 7 & Pin 6	732.0E+6	166.4E+6	4.0E+3	20.0E+3
ARA2812S	12.0 to 13.2	Pin 7 & Pin 5	5.0E+9	331.8E+6	10.5E+3	126.3E+3
	10.8 to 12.0	Pin 7 & Pin 6	2.0E+9	300.7E+6	4.2E+3	50.5E+3
ARA2815S	15.0 to 16.5	Pin 7 & Pin 5	6.0E+9	316.0E+6	10.0E+3	150.0E+3
	13.5 to 15.0	Pin 7 & Pin 6	2.4E+9	326.4E+6	4.0E+3	60.0E+3

Application Notes:

See Application Note AN-1204 for the following:

1. Overload/short circuit power dissipation.
2. Output filtering.
3. Attachment of converter.

Mechanical Outline

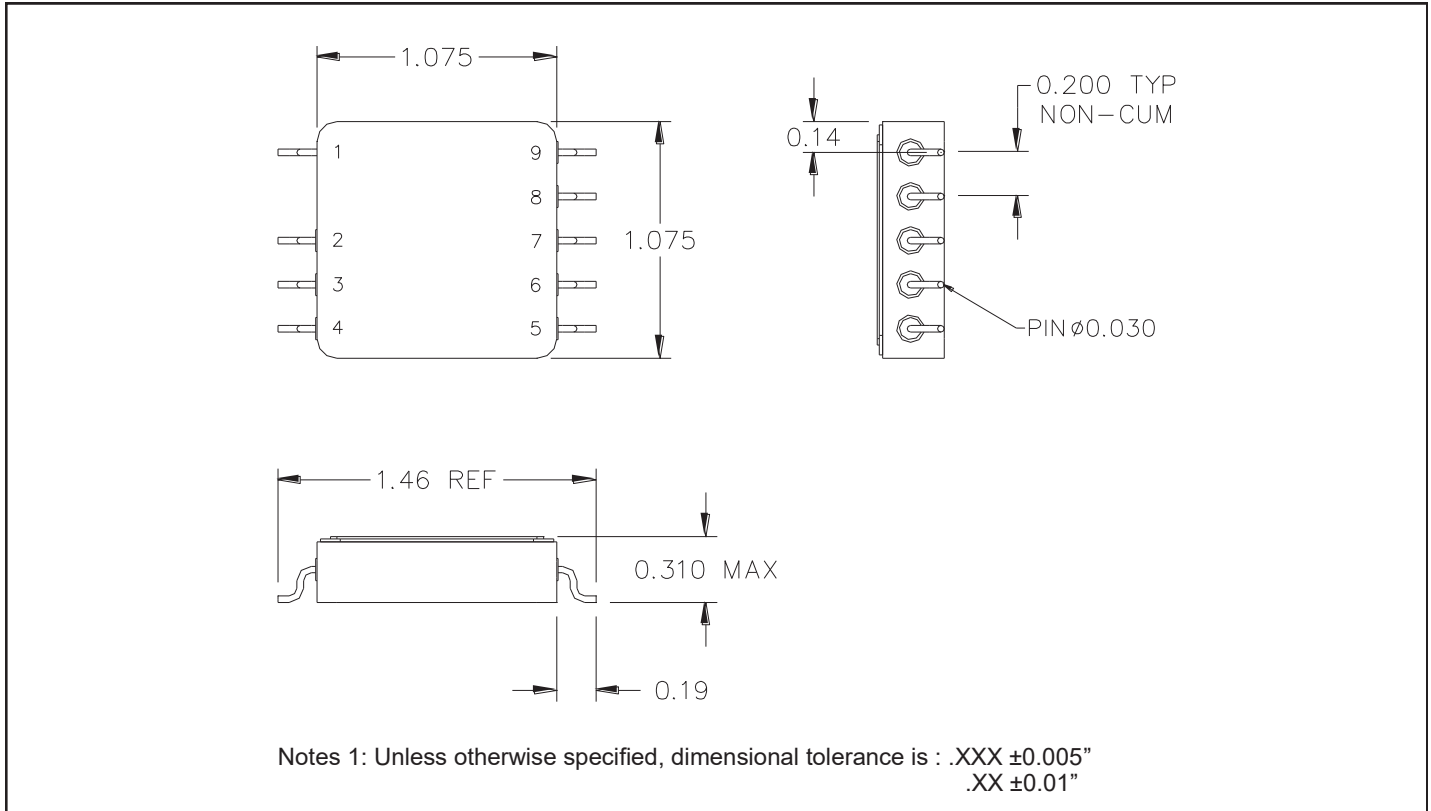

Block Diagram

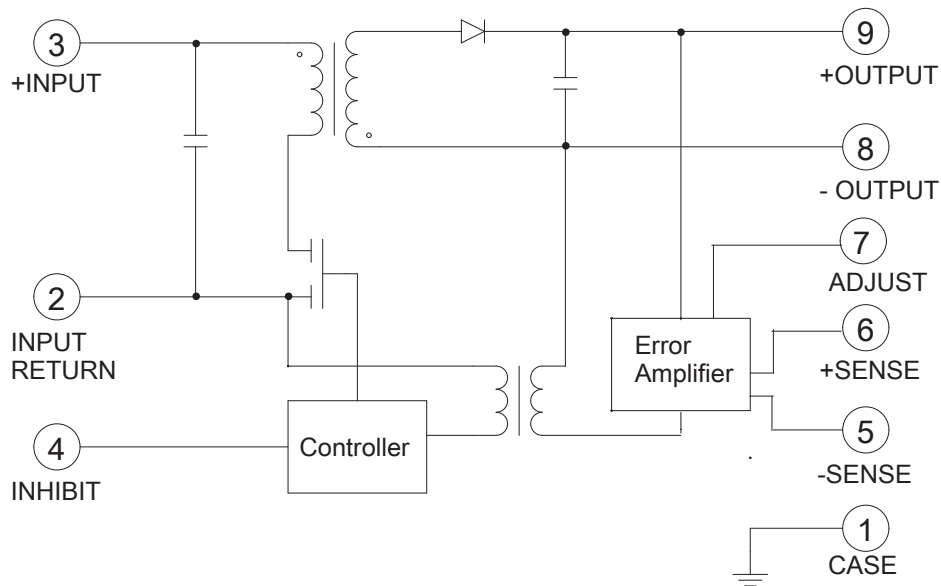

Pin Designation

Pin #	Designation	Pin #	Designation
1	Case Ground	6	+ Sense
2	Input Return	7	Adjust
3	+ Input	8	- Output
4	Inhibit	9	+ Output
5	- Sense		

Device Screening

Part Number Designator		/EM ①	/CK ②
Compliance Level	MIL-PRF-38534	—	K level compliant
Certification Mark		—	CK
Screening Requirement	MIL-STD-883 Method	—	—
Temperature Range	—	Room Temperature	-55°C to +85°C
Element Evaluation	MIL-PRF-38534	N/A	Class K
Non-Destructive Bond Pull	2023	N/A	Yes
Internal Visual	2017	IR Defined	Yes
Temperature Cycle	1010	N/A	Cond C
Constant Acceleration	2001, Y1 Axis	N/A	3000 Gs
PIND	2020	N/A	Cond A
Burn-In	1015	N/A	320 hrs @ 125°C (2 x 160 hrs)
Final Electrical (Group A)	MIL-PRF-38534 & Specification	Room Temperature	-55°C, +25°C, +85°C
PDA	MIL-PRF-38534	N/A	2%
Seal, Fine and Gross	1014	N/A	Cond CH
Radiographic	2012	N/A	Yes
External Visual	2009	IR Defined	Yes

Notes:

- ① **"EM" grade** parts are strictly intended to permit the customer to determine the electrical functionality of the device in the customer's application in ambient conditions. The use of EM devices in production applications presents an unquantifiable risk of failure and IR HiRel disclaims all responsibility for such failure.
- ② **"CK" grade** is the flight model (FM) compliant to K Level screening as defined in the DLA Land and Maritime MIL-PRF-38534 requirements, but is not necessarily a DLA Land and Maritime qualified SMD per MIL-PRF-38534. The governing document for this part number designator is the IR HiRel datasheet (this document). Radiation rating as stated in the "Radiation Performance Characteristics" section, is verified by analysis and test per IR HiRel internal procedure. The part is marked with the IR base part number and the "CK" certification mark.

Part Numbering

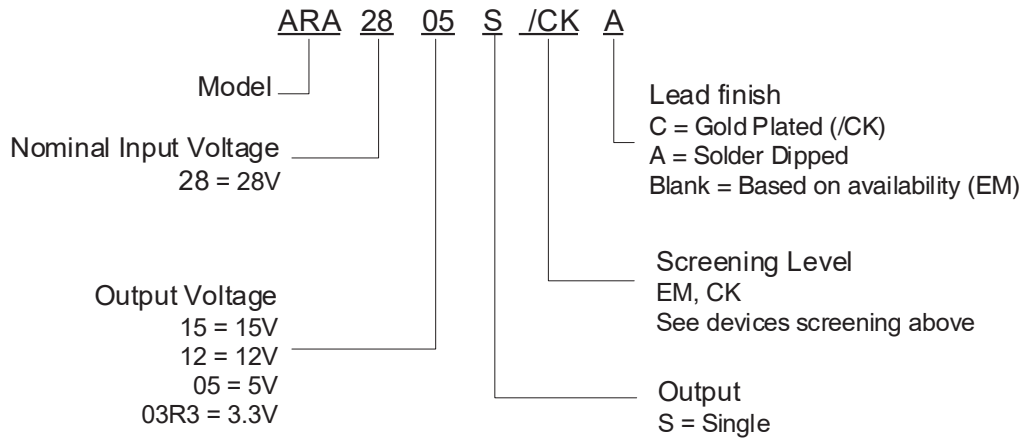

one source. one solution.®

Americas: 1.855.426.6766

EMEA & APAC: +44 (0) 1603.788967

China: +85 21.5459.1970

India: +91 7760.990.545

Micross Components reserves the right
to change products or specifications without notice.

Data and specifications subject to change without notice.