

ARA-SERIES

PD-97904D

Hybrid – High Reliability Radiation Hardened Low Power DC-DC Converter 100V Input, Single and Dual Output

Features

- Total Dose guaranteed to 100 kRads(Si)
- SEE Hardened to LET up to 82 MeV·cm²/mg
- Low Weight < 15grams
- Magnetically Coupled Feedback
- 65V to 120V DC Input Range
- Up to 5W Output Power
- Single and Dual Output Models
Include 3.3, 5, 12, 15, ±5, ±12 and ±15V
- Low Quiescent Current
- High Efficiency - to 80%
- -55°C to +85°C Operating Temperature Range
- 100MΩ @ 200VDC Isolation
- Under-Voltage Lockout
- Short Circuit and Overload Protection
- External Inhibit
- Output Adjustment (For both Single and Dual Output Models)
- Remote Sense on Single Output Models

Product Summary

- **Part number:** ARA10003R3S, ARA10005S, ARA10012S, ARA10015S, ARA10005D, ARA10012D, ARA10015D

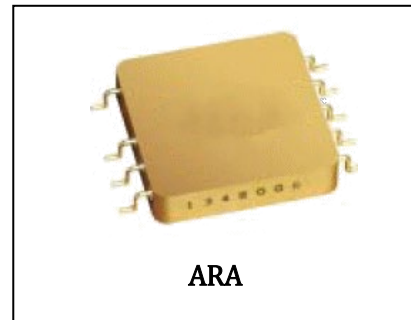

Potential Applications

- Geostationary Earth Orbit Satellites (GEO)
- Deep Space Satellites / Probes

Product Validation

Validated according to MIL-PRF- 38534 for high-reliability applications

Orderable Part Numbers and DLA SMD Numbers

If a DLA SMD is available as listed in the table below, such model shall be ordered using the DLA SMD number. Otherwise the model shall be ordered using the part number nomenclature

Table 1 **Ordering Information**

ARA-SERIES

100V Input, Single and Dual Output

Description, Circuit Description and Design Methodology

Reference IR Base Model	Orderable Part Number	Lead finish
ARA10003R3S/CKA	ARA10003R3S/CKA	Solder Dipped
ARA10003R3S/CKC	ARA10003R3S/CKC	Gold Plated
ARA10005S/CKA	ARA10005S/CKA	Solder Dipped
ARA10005S/CKC	ARA10005S/CKC	Gold Plated
ARA10012S/CKA	ARA10012S/CKA	Solder Dipped
ARA10012S/CKC	ARA10012S/CKC	Gold Plated
ARA10015S/CKA	ARA10015S/CKA	Solder Dipped
ARA10015S/CKC	ARA10015S/CKC	Gold Plated
ARA10005D/CKA	ARA10005D/CKA	Solder Dipped
ARA10005D/CKC	ARA10005D/CKC	Gold Plated
ARA10012D/CKA	ARA10012D/CKA	Solder Dipped
ARA10012D/CKC	ARA10012D/CKC	Gold Plated
ARA10015D/CKA	ARA10015D/CKA	Solder Dipped
ARA10015D/CKC	ARA10015D/CKC	Gold Plated

Description, Circuit Description and Design Methodology

Description

The ARA100 Series of DC-DC converters are low power radiation hardened, high reliability devices designed for radiation environments such as those encountered by geostationary earth orbit satellites, deep space probes and communication systems. Features include small size, high efficiency, low weight and a high tolerance to total ionizing dose, single event effects and environmental stresses such as temperature extremes, mechanical shock, and vibration. Extensive documentation including Radiation test reports, Thermal Analysis, Stress Analysis and MTBF are available.

The ARA100 Series converters incorporate a fixed frequency flyback topology with magnetic feedback. All models include an external inhibit port. They ARA encased in a hermetic 1.20" x 1.20" x 0.31" AlSi package and

ARA-SERIES

100V Input, Single and Dual Output

Circuit Description

weigh less than 15 grams. The package utilizes rugged ceramic feed-through copper core pins and is hermetically sealed using laser welding.

Environmental screening includes temperature cycling, constant acceleration, fine and gross leak, and burn-in as specified by MIL-PRF-38534 for class K hybrids.

Non-flight versions of the ARA-Series converters ARA available for system development purposes. Variations in electrical specifications and screening to meet custom requirements can be accommodated

Circuit Description

The ARA100 Series converters utilize a flyback topology with a nominal switching frequency of 400 kHz. Electrical isolation and tight output regulation are achieved through the use of a magnetically coupled feedback.

Output current is limited under any load fault condition to approximately 165% of rated. The converter will resume normal operation when the load current is reduced below the current limit point. This protects the converter from both overload and short circuit conditions. There are no latching elements included in the load fault protection circuits to eliminate the possibility of falsely triggering the protection circuits during single event radiation exposure.

An under-voltage lockout circuit prohibits the converter from operating when the line voltage is too low to maintain the output voltage. The converter will not start until the line voltage rises to approximately 59 volts and will shut down when the input voltage drops below 57 volts. The hysteresis reduces the possibility of line noise interfering with the converter's start-up and shut down circuitry.

An external inhibit port is provided to control converter operation. The converters' s operation is inhibited when this pin is pulled low. It is intended to be driven by an open collector device. The pin may be left open for normal operation and has a nominal open circuit voltage of about 12.75V.

Design Methodology

The ARA Series was developed using a proven conservative design methodology, which includes selecting radiation tolerant, and established reliability components and fully de-rating to the requirements of MIL-STD-975, MIL-STD-1547, and NASA EE-INST-002. Conservative de-rating of the radiation-hardened power MOSFET virtually eliminates the possibility of SEGR and SEB. A magnetic feedback circuit is utilized instead of opto-couplers to minimize temperature, radiation and aging sensitivity. PSPICE was used extensively to predict and optimize circuit performance for both beginning and end-of-life. Thorough design analyses include Radiation Susceptibility, Worst Case, Stress, Thermal, Failure Modes and Effects (FMEA) and Reliability (MTBF).

Table of contents

Features	1
Product Summary	1
Potential Applications	1
Product Validation	1
Orderable Part Numbers and DLA SMD Numbers	1
Description, Circuit Description and Design Methodology	2
Description	2
Circuit Description	3
Design Methodology	3
Table of contents	3
1 Specification and Electrical Performance	5

1.1	Maximum and Operating Table	5
1.2	Electrical Performance Characteristics	5
2	Block Diagram and Figures for Load Regulation	9
3	Efficiency Curves	10
4	Radiation Performance table and Input Ripple Current.....	13
4.1	Radiation Performance table	13
4.2	ARA Series Input Ripple Current:	13
5	Mechanical Outlines	15
6	Pin Designation.....	16
6.1	Pin Designation (Single / Dual)	16
7	Devices Screening	17
	Part Numbering.....	18
	Revision history	19

Specification and Electrical Performance

1 Specification and Electrical Performance

1.1 Maximum and Operating Table

Table 2 Absolute Maximum Rating and Recommended Operating Conditions

Absolute Maximum Rating		Recommended Operating Conditions	
Input voltage	-0.5V _{DC} to +120V _{DC}	Input voltage	+65V _{DC} to +110V _{DC}
Output power	Internally limited	Output power	0 to Max. Rated
Lead Temperature	+300°C for 10 seconds		
Operating Temperature	-55°C to +125°C	Operating Temperature	-55°C to +85°C
Storage Temperature	-55°C to +135°C	Operating Temperature ¹	-55°C to +70°C

1.2 Electrical Performance Characteristics

Table 3 Electrical Characteristics

Parameter	Group A Subgroups	Conditions -55°C ≤ T _C ≤ +85°C V _{IN} = 100V DC ± 5%, C _L = 0uF unless otherwise specified	Limits			Unit	
			Min	Nom	Max		
Input voltage (V _{IN})			65	100	110	V	
Output Voltage (V _{OUT})							
ARA10003R3S	1, 2,3	I _{OUT} = 100% rated load Note 4	3.27	3.30	3.33	V	
ARA10005S	1, 2,3		4.95	5.00	5.05		
ARA10012S	1, 2,3		11.88	12.0	12.12		
ARA10015S	1, 2,3		14.85	15.0	15.15		
ARA10005D	1, 2,3		±4.95	±5.00	±5.05		
ARA10012D	1, 2,3		±11.88	±12.0	±12.12		
ARA10015D	1, 2,3		±14.85	±15.0	±15.15		
Output power (P _{OUT})							
ARA10003R3S	1,2,3	V _{IN} = 65, 100, 110 Volts, Note 2	0		4.0	W	
All Others			0		5.0		
Output current (I _{OUT})							
ARA10003R3S	1,2,3	V _{IN} = 65, 100, 110 Volts, Note 2	0		1.21	A	
ARA10005S			0		1.0		
ARA10012S			0		0.416		
ARA10015S			0		0.333		
ARA10005D			Either Output, Note 3	0			0.8
ARA10012D			Either Output, Note 3	0			0.33
ARA10015D			Either Output, Note 3	0			0.27

For Notes to Electrical Performance Characteristics, refer to page 9

Line regulation (V _{RLINE})	1,2,3	V _{IN} = 65, 100, 110 Volts I _{OUT} = 0, 50%, 100% rated, Notes 1, 4	-0.50		0.50	%
---------------------------------------	-------	--	-------	--	------	---

¹ Meets de-rating per MIL-STD-975, MIL-STD-1547, NASA EEE-INST-002 when Vin nominal is 100V and Vin worst case is 110V. (Note 13)

ARA-SERIES
100V Input, Single and Dual Output

Specification and Electrical Performance

Parameter	Group A Subgroups	Conditions -55°C ≤ T _c ≤ +85°C V _{IN} = 100V DC ± 5%, C _L = 0uF unless otherwise specified	Limits			Unit
			Min	Nom	Max	
Load regulation (V _{RLOAD})	1,2,3	I _{OUT} = 0, 50%, 100% rated, Notes 1, 4 V _{IN} = 65, 100, 110 Volts	-1.0		1.0	%
Total regulation (V _{RLOAD})	1,2,3	V _{IN} = 65, 100, 110 Volts I _{OUT} = 0, 50%, 100% rated, Dual Model is measured from + Output to -Output, Note 14	-1.0		1.0	%
Cross regulation (V _{RCROSS}) ARA10005D ARA10012D ARA10015D	1,2,3	Duals only, Note 5 V _{IN} = 65, 100, 110 Volts	-3.5 -3.0 -2.5		3.5 3.0 2.5	%
Input current (I _{IN})	1,2,3	I _{OUT} = 0, Pin 3 open Pin 4 shorted to Pin 2			8.0 1.5	mA
Switching frequency (F _S)	1,2,3	Sync. Input (Pin 4) open	350	400	475	kHz
Output ripple (V _{RIP}) ARA10003R3S ARA10005S ARA10012S ARA10015S ARA10005D ARA10012D ARA10015D	1,2,3	V _{IN} = 65, 100, 110 Volts I _{OUT} = 100% rated load Notes 4, 6			35 50 50 50 50 50 50	mV _{p-p}
Efficiency (E _{FF}) ARA10003R3S ARA10005S ARA10012S ARA10015S ARA10005D ARA10012D ARA10015D	1,2,3	I _{OUT} = 100% rated load Notes 4	65 71 75 75 73 74 74	71 75 79 80 75 77 78		%

For Notes to Electrical Performance Characteristics, refer to page 9

Enable Input/Inhibit Input			11		14	V
open circuit voltage	1,2,3	Note 1			800	μA
drive current (sink)			-0.7		50	V
voltage range						
Current Limit Point	1,2,3	V _{OUT} = 90% of Nominal,	105		200	%

ARA-SERIES
100V Input, Single and Dual Output

Specification and Electrical Performance

Parameter	Group A Subgroups	Conditions -55°C ≤ T _c ≤ +85°C V _{IN} = 100V DC ± 5%, C _L = 0uF unless otherwise specified	Limits			Unit
			Min	Nom	Max	
Expressed as a percentage of full rated load current		Note 4				
Power dissipation, load fault (P _D) ARA10003R3S ARA10005S ARA10012S ARA10015S ARA10005D ARA10012D ARA10015D	1,2,3	Short Circuit, Overload, Note 8			3.5 3.5 3.5 3.5 3.0 3.0 3.0	W
Under Voltage Threshold Release (On) (UVR) Lockout (OFF) Hysteresis (UVLO)	1,2,3		51 0.5		61	V
Output response to step load changes (V _{TLD})	4,5,6	Half Load to/from Full Load, Notes 4,9	-300		300	mVpk
Recovery time, step load changes (T _{TLD})	4,5,6	Half Load to/from Full Load, Notes 4,9,10			200	μs
Output response to step line changes (V _{TLN})	4,5,6	65V to/from 110V I _{OUT} = 100% rated load, Notes 1,4,11	-300		300	mVpk
Recovery time, step line changes (T _{TLN})	4,5,6	65V to/from 110V I _{OUT} = 100% rated load, Notes 1,4,10,11			200	μs
Turn-on Response Overshoot (V _{OS}) Turn-on Delay (T _{DLY})	4,5,6	No Load, Full Load Notes 4,12	1.5		500 10	mV ms

For Notes to Electrical Performance Characteristics, refer to page 9

Capacitive Load (C _L) ARA10003R3S ARA10005S ARA10012S ARA10015S ARA10005D	1	I _{OUT} = 100% rated load No effect on DC performance Notes 1,4,7			1000 700 100 80 300	μF
--	---	--	--	--	---------------------------------	----

Specification and Electrical Performance

Parameter	Group A Subgroups	Conditions $-55^{\circ}\text{C} \leq T_c \leq +85^{\circ}\text{C}$ $V_{IN} = 100\text{V DC} \pm 5\%$, $C_L = 0\mu\text{F}$ unless otherwise specified	Limits			Unit
			Min	Nom	Max	
ARA10012D ARA10015D		Each output on duals			90 60	
Line Rejection	1	$I_{OUT} = 100\%$ rated load DC to 50kHz, Notes 1, 4		50		dB
Isolation	1	Input to Output or Any Pin to Case except Pin 1, test @ 200VDC	100			MΩ
Device Weight					15	g
MTBF		MIL-HDBK-217F2, SF, 35°C	8.0×10^6			Hrs

Notes: Electrical Performance Characteristics Table

1. Parameter is tested as part of design characterization or after design changes. Thereafter, parameter shall be guaranteed to the limits specified.
2. Parameter verified during line and load regulation tests.
3. Output load current must be distributed such that at least 20% of the total load current is being provided by one of its outputs.
4. Load current split equally between outputs on dual output models.
5. Cross regulation is measured with 20% rated load on output under test while changing the load on the other output from 20% to 80% of rated.
6. Guaranteed for a D.C. to 20MHz bandwidth. Tested using a 20kHz to 10MHz bandwidth.
7. Capacitive load may be any value from 0 to the maximum limit without compromising dc performance.
8. Overload power dissipation is defined as the device power dissipation with the load set such that $V_{OUT} = 90\%$ of nominal.
9. Load step transition time $\geq 10 \mu\text{s}$.
10. Recovery time is measured from the initiation of the transient to where V_{OUT} has returned to within $\pm 1\%$ of its steady state value.
11. Line step transition time $\geq 100 \mu\text{s}$.
12. Turn-on delay time from either a step application of input power or a logic low to a logic high transition on the inhibit pin (pin 3) to the point where $V_{OUT} = 90\%$ of nominal.
13. For ceramic capacitors with voltage stress less than 10V, derating requirements require minimum 100V rated capacitors. The product will use capacitors with a minimum rating of 16V.
14. Total regulation is $\pm 3\%$ for end of life.

Block Diagram and Figures for Load Regulation

2 Block Diagram and Figures for Load Regulation

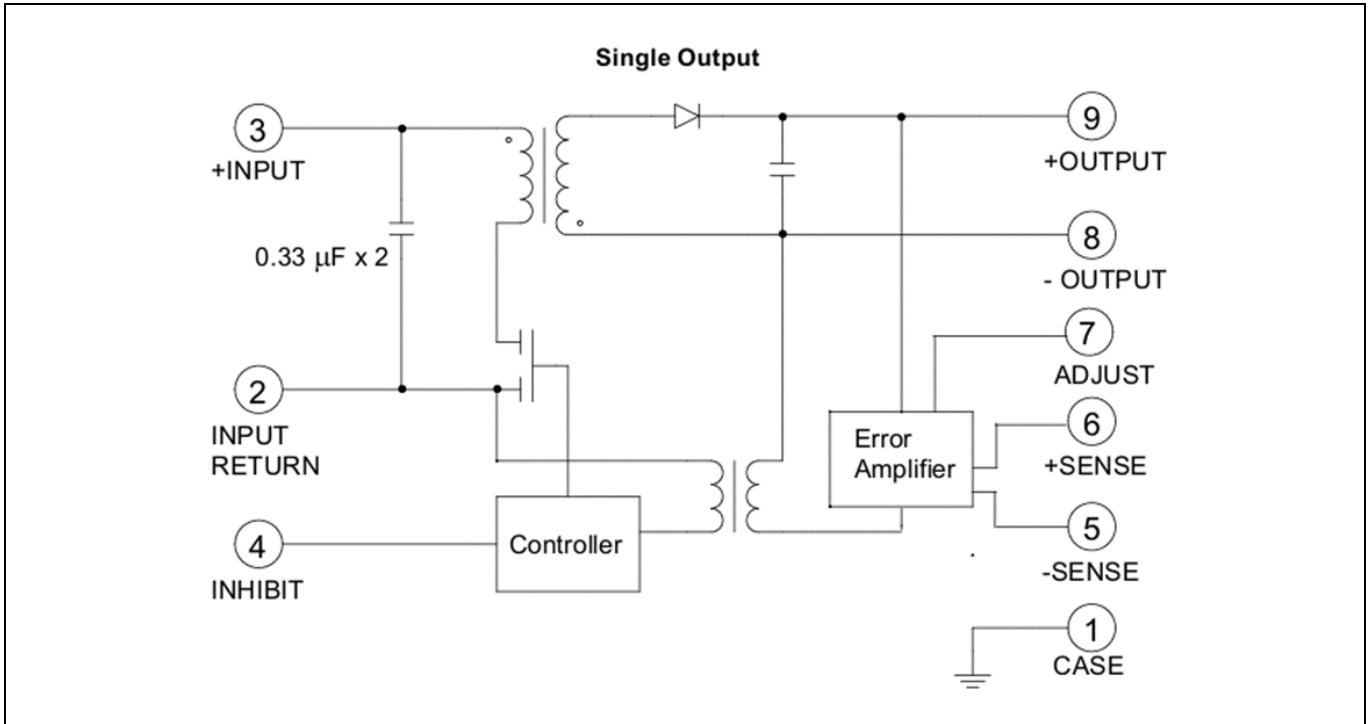

Figure 1 Block Diagram - Single Output

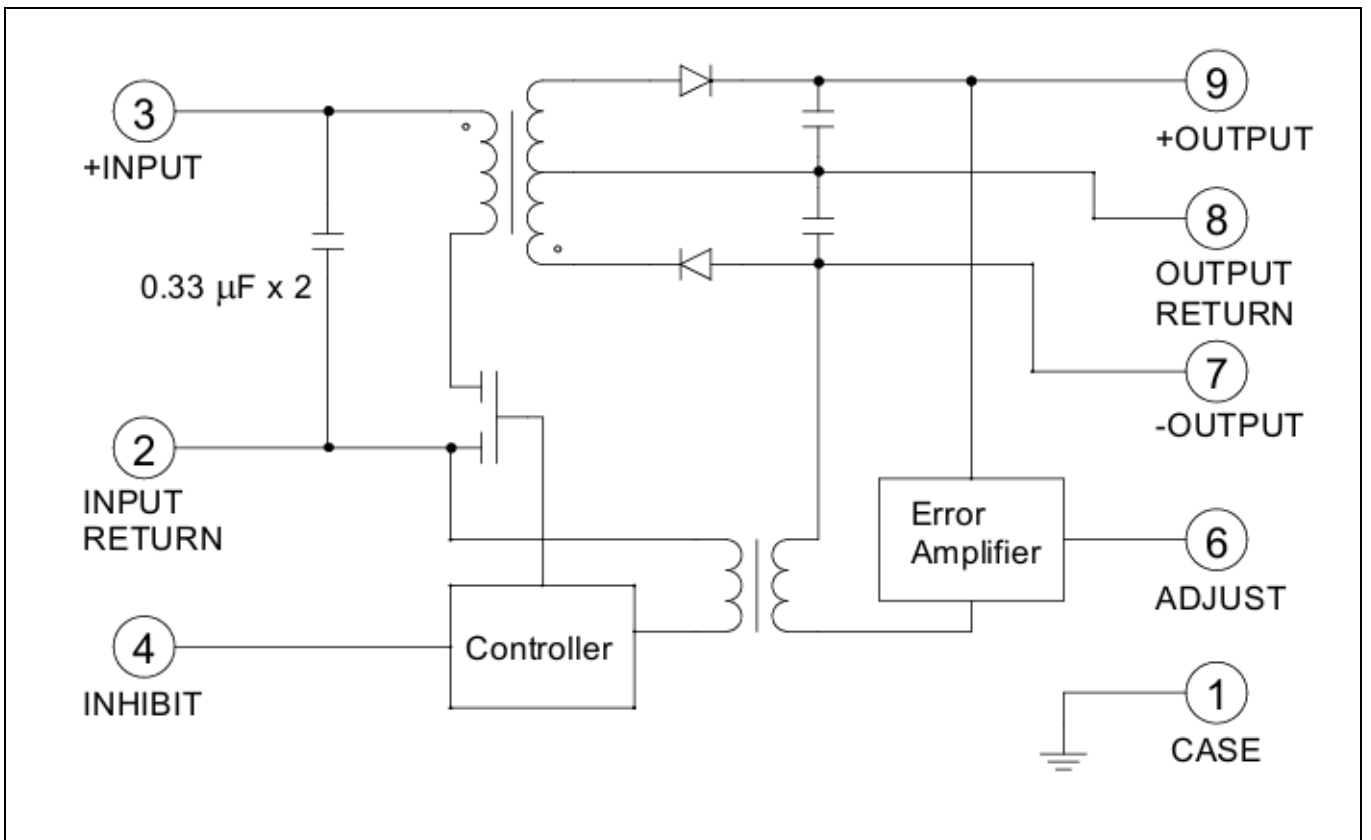

Figure 2 Block Diagram - Dual Output

Efficiency Curves

3 Efficiency Curves

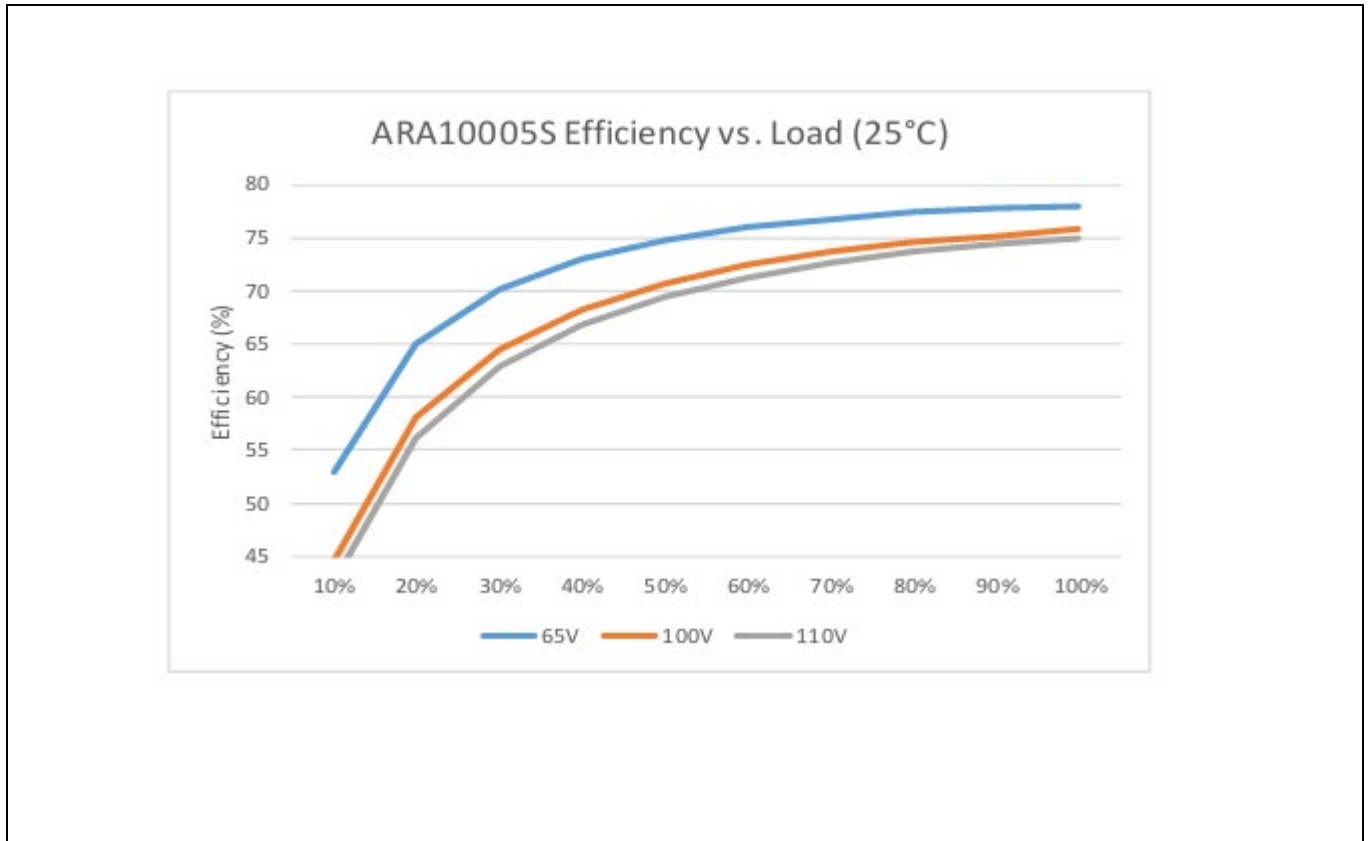

Figure 3 ARA10005S Efficiency vs. Load (25°C)



Figure 4 ARA10005S Efficiency vs. Load (100V input)

Efficiency Curves

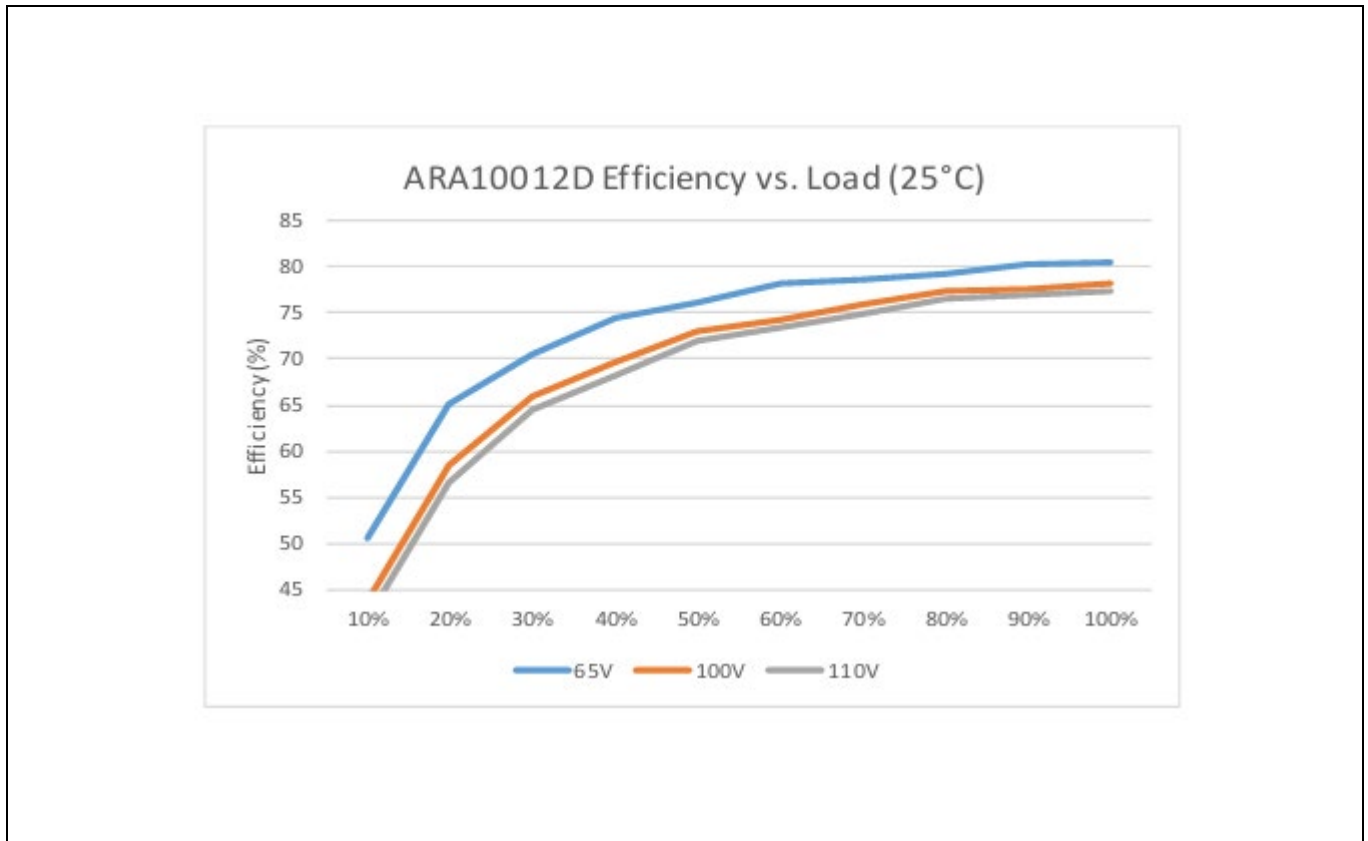

Figure 5 ARA10012D Efficiency vs. Load (25°C)

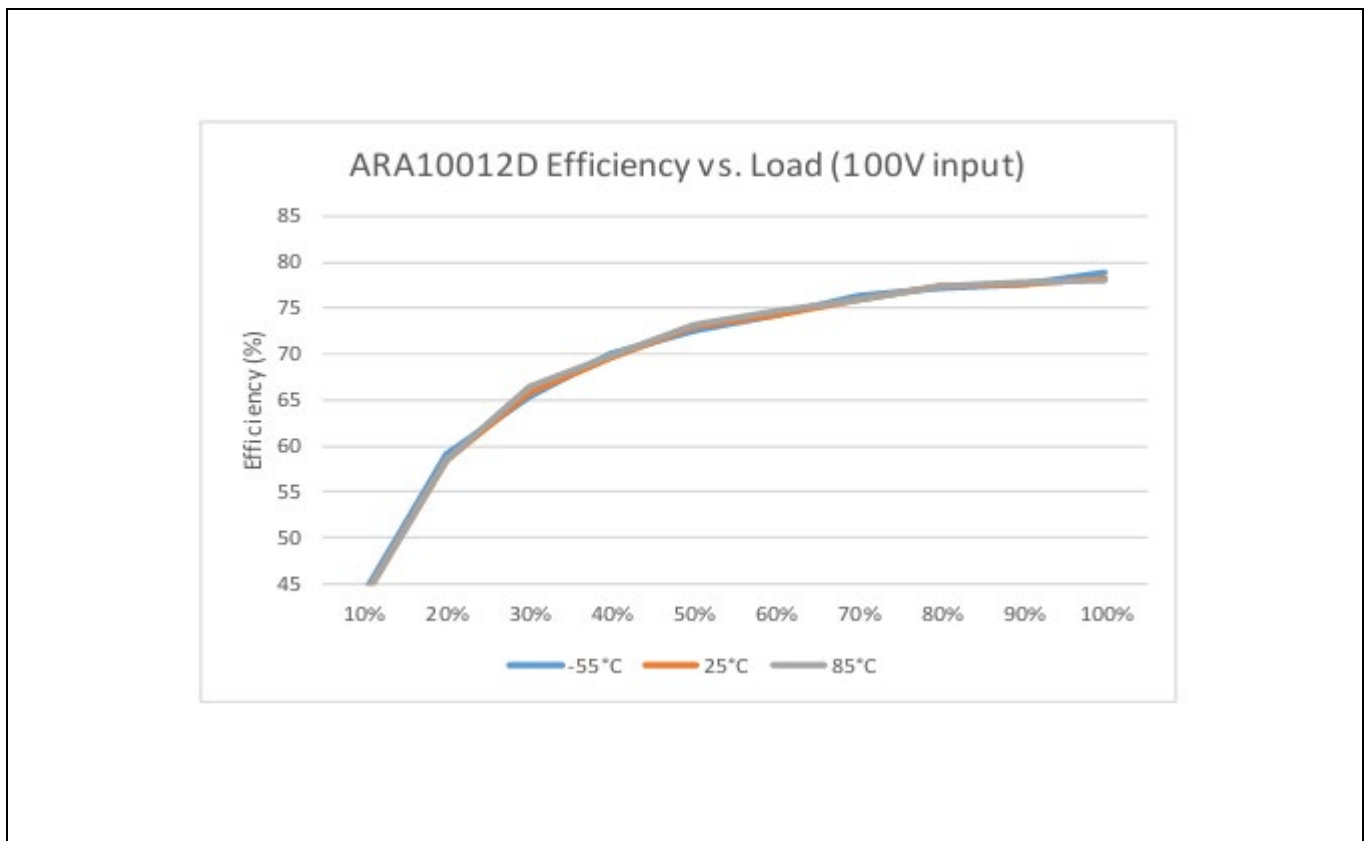

Figure 6 ARA10012D Efficiency vs. Load (100V input)

Efficiency Curves



Figure 7 ARA10015D Efficiency vs. Load (25°C)

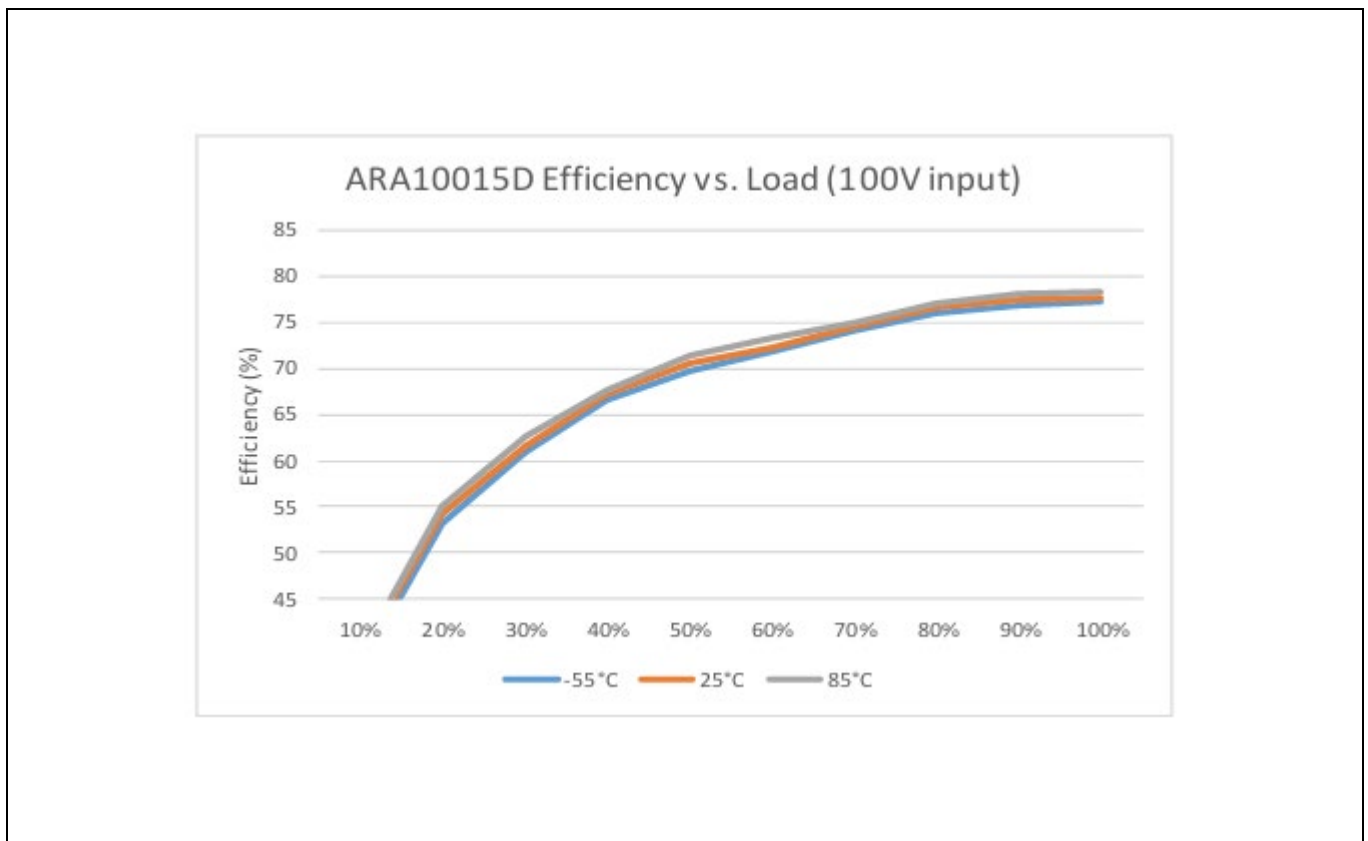

Figure 8 ARA10015D Efficiency vs. Load (100V input)

Radiation Performance table and Input Ripple Current

4 Radiation Performance table and Input Ripple Current

4.1 Radiation Performance table

Table 4 Radiation Performance Characteristics

Test	Conditions	Min	Typ	Max	Unit
Total Ionizing Dose (Gamma)	T _C = 25°C, Dose Rate = 14 - 50 Rads/s (Si) Operating bias applied during exposure, Half Rated Load, V _{IN} = 100V	100		150	kRads (Si)
Single Event Effects SEU, SEL, SEGR, SEB ₁	Heavy ions (LET) Operating bias applied during exposure, Full Rated Load, V _{IN} = 65V, 100V, 110V ²	82			MeV·cm ² /mg

4.2 ARA Series Input Ripple Current:

In the ARA Series converters, as shown in the Block diagrams (page 10), there is no series inductor before the input capacitor. Therefore, when measuring the input ripple current, it is dependent on the series impedance between the power source and the converter input. For input ripple current measurements, a set-up with a known inductor value and a large capacitor connected between the power source and an ARA converter should be used. The capacitor is used to minimize the source impedance supplying the converter. A ripple current is measured with a current probe connected between the converter and the large capacitor. In order to reduce the input ripple current, the AF100461 filter may be used between the source voltage and the ARA Series converters.

A) ARA Series Output Voltage Adjustment:

Output of ARA Series can be adjusted to be greater or less than the nominal output voltage with an external resistor. However, the ranges of the output voltages are limited depending on the model as specified in Table 5 and 6. An approximate value of the resistor can be determined using the following formula

For Single Output Model: $R_{adj} = [A - (B \times V_{out})] / [(C \times V_{out}) - D]$

For Dual Output Model: $R_{adj} = [A - (B \times 2V_{out})] / [(C \times 2V_{out}) - D]$

Where:

R_{adj} is the value of the external resistor in ohms and is connected as specified in Table 5 and 6. Power rating of the resistor shall be $\geq 0.125W$. A Metal film resistor with temperature coefficient a of $\leq \pm 50$ ppm and tolerance of $\leq 1\%$ is recommended. However, the final selection is dependent on specific design requirements.

V_{out} is the desired output voltage in volts.

A, B, C, and D are unique constants depending on the model as shown in Table 1 for Single Output models and Table 6 for Dual Output models.

¹ Output perturbation is less than + 5% / -8% of nominal output voltage.

² Beam conditions: LET = 82 MeV·cm²/mg.

Radiation Performance table and Input Ripple Current

Table 5 Single Output Voltage Ranges, Constants and Resistor connection by Model

Model	Output Voltage Range	Radj connection between	A	B	C	D
ARA10003R3S	3.3 to 3.6	Pin 7 & Pin 5	122.4E+6	12.0E+6	10.0E+3	33.3E+3
ARA10005S	5.0 to 5.5	Pin 7 & Pin 5	1.8E+9	300.0E+6	10.0E+3	50.0E+3
	4.5 to 5.5	Pin 7 & Pin 6	700.0E+6	160.0E+6	4.0E+3	20.0E+3
ARA10012S	12.0 to 13.2	Pin 7 & Pin 5	4.8E+9	315.0E+6	10.5E+3	126.3E+3
	10.8 to 12.0	Pin 7 & Pin 6	1.9E+9	294.0E+6	4.2E+3	50.5E+3
ARA10015S	15.0 to 16.5	Pin 7 & Pin 5	5.8E+9	300.0E+6	10.0E+3	150.0E+3
	13.5 to 15.0	Pin 7 & Pin 6	2.3E+9	320.0E+6	4.0E+3	60.0E+3

Table 6 Dual Output Voltage Ranges, Constants and Resistor connection by Model

Model	Output Voltage Range	Radj connection between	A	B	C	D
ARA10005D	5.0 to 5.5	Pin 6 & Pin 7	3.8E+9	300.0E+6	10.0E+3	100.0E+3
	4.5 to 5.5	Pin 6 & Pin 9	1.5E+9	240.0E+6	4.0E+3	40.0E+3
ARA10012D	12.0 to 13.2	Pin 6 & Pin 7	9.4E+9	300.0E+6	10.0E+3	240.0E+3
	10.8 to 12.0	Pin 6 & Pin 9	3.7E+9	464.0E+6	4.0E+3	96.0E+3
ARA10015D	15.0 to 16.5	Pin 6 & Pin 7	11.8E+9	300.0E+6	10.0E+3	300.0E+3
	13.5 to 15.0	Pin 6 & Pin 9	4.7E+9	560.0E+6	4.0E+3	120.0E+3

Mechanical Outlines

5 Mechanical Outlines

Note: For the most updated package outline, please see the website: [ARA-SERIES](#)

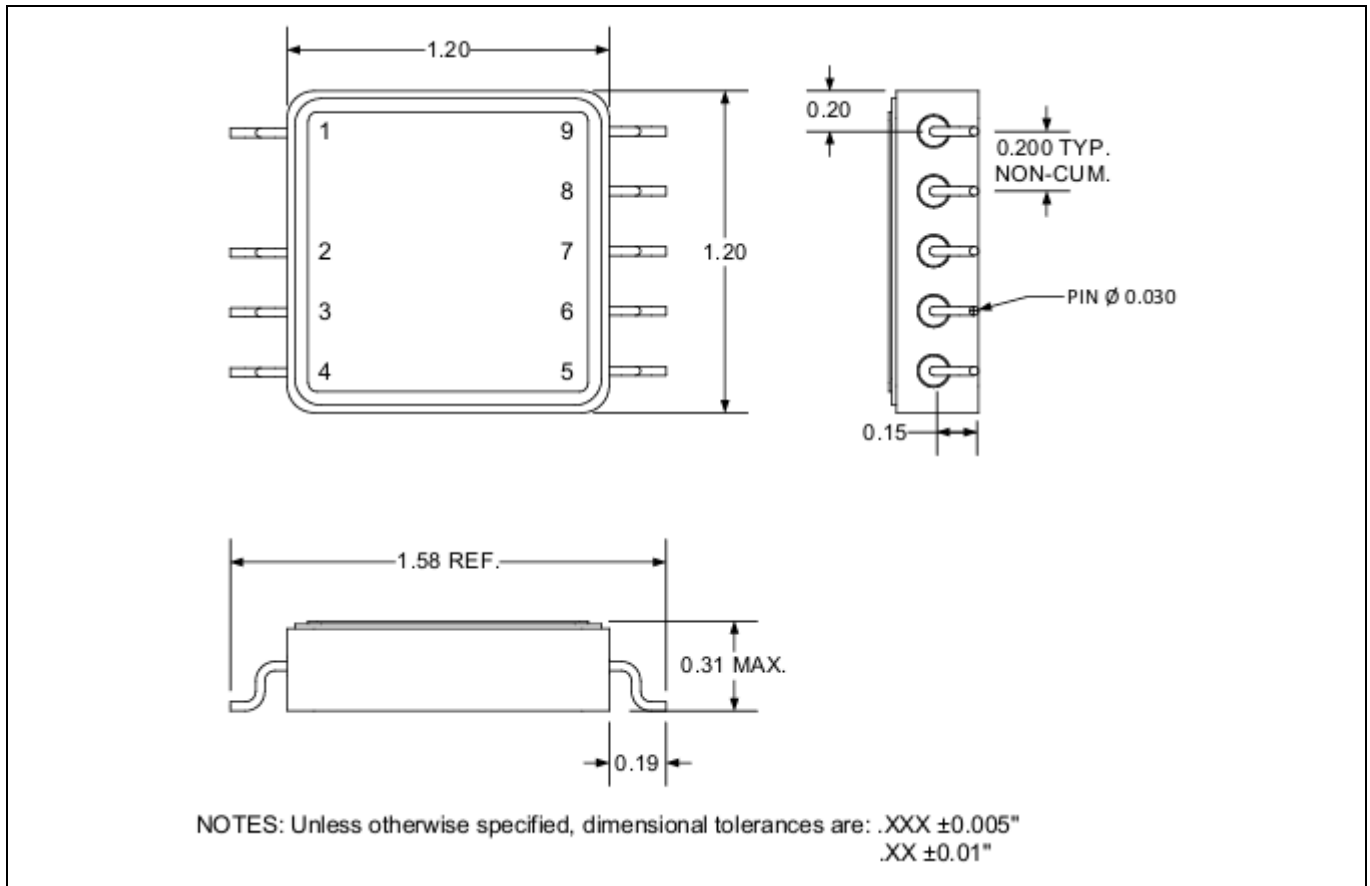

Figure 9 Package outline

Pin Designation

6 Pin Designation

6.1 Pin Designation (Single / Dual)

Table 7 Single Output

Pin Number	Designation
1	Case Ground
2	Input Return
3	+Input
4	Inhibit
5	- Sense
6	+ Sense
7	Adjust
8	- Output
9	+ Output

Dual Output

Pin Number	Designation
1	Case Ground
2	Input Return
3	+Input
4	Inhibit
5	NC
6	Adjust
7	- Output
8	Output Return
9	+ Output

Devices Screening

7 Devices Screening

Part Number Designator		/EM ^①	/CK ^②
Compliance Level	MIL-PRF-38534	—	K level compliant
Certification Mark		—	CK
Screening Requirement	MIL-STD-883 Method	—	—
Temperature Range	—	Room Temperature	-55°C to +85°C
Element Evaluation	MIL-PRF-38534	N/A	Class K
Non-Destructive Bond Pull	2023	N/A	Yes
Internal Visual	2017	IR Defined	Yes
Temperature Cycle	1010	N/A	Cond C
Constant Acceleration	2001, Y1 Axis	N/A	3000 Gs
PIND	2020	N/A	Cond A
Burn-In	1015	N/A	320 hrs @ 125°C (2 x 160 hrs)
Final Electrical (Group A)	MIL-PRF-38534 & Specification	Room Temperature	-55°C, +25°C, +85°C
PDA	MIL-PRF-38534	N/A	2%
Seal, Fine and Gross	1014	N/A	Cond CH
Radiographic	2012	N/A	Yes
External Visual	2009	IR Defined	Yes

Notes:

- ① **EM” grade** shall only be form, fit and function equivalent to its Flight Model (FM) counterpart for electrical evaluation, and it may not meet the radiation performance. The EM Model shall not be expected to comply with MIL-PRF-38534 flight quality/workmanship standards, and configuration control. An EM build may use electrical equivalent commercial grade components
- ② **”CK” grade** is the flight model (FM) compliant to K Level screening as defined in the DLA Land and Maritime MIL-PRF-38534 requirements, but is not necessarily a DLA Land and Maritime qualified SMD per MIL-PRF-38534. The governing document for this part number designator is the IR HiRel datasheet (this document). Radiation rating as stated in the “Radiation Performance Characteristics” section, is verified by analysis and test per IR HiRel internal procedure. The part is marked with the IR base part number and the “CK” certification mark.
- * The DCDC converter models identified in this datasheet reflect the capability of the Series with at least one model fully compliant to the MIL-PRF-38534 Class K requirements and other models available as IR HiRel Space Grade by similarity per MIL-PRF-38534.
- * IR Space Grade model availability and model specific documentation availability depends on the model. Any model listed in this datasheet and not previously manufactured can be developed on demand by similarity on customer's request using the same proven design rules, component and material type, component derating, production flow, processes and process control validated and qualified for the MIL-PRF-38534 Class K SMD compliant models of the Series per IR HiRel internal procedure. IR HiRel design by similarity meets or exceeds MIL-PRF-38534 device similarity requirements.

ARA-SERIES

100V Input, Single and Dual Output

Part Numbering

Part Numbering

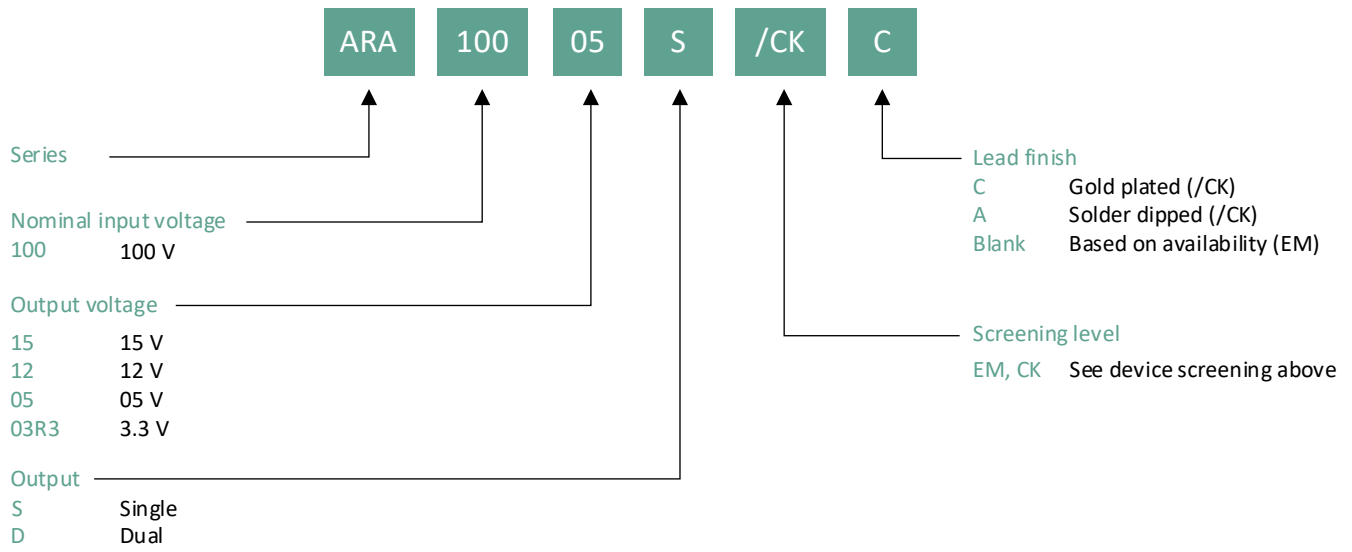

Revision history

Revision history

Document version	Date of release	Description of changes
	07/27/2018	Datasheet (PD-97904)
Rev A	10/15/2019	Updated based on ECO-1110_29453
Rev B	09/02/2020	Updated based on ECO-1110_29731
Rev C	12/09/2021	Updated based on ECO-1110_30622
Rev D	08/31/2022	Updated based on ECO-1110_30800

Need Information?